



TPI CORPORATION

America's Comfort Conditioning Company



Tel: 1-800-682-3398 | 1-423-477-4131 | Fax: 1-423-477-0064 | www.tpicorp.com

2019 ELECTRICAL PRODUCTS CATALOG



FANS

VENTILATION, FANS, & INDUSTRIAL LIGHTING
INDUSTRIAL - COMMERCIAL - RESIDENTIAL

© Copyright 2019; TPI Corporation, P.O. Box 4973, Johnson City, TN 37602
November 1, 2018: Distribution Products Catalog - REV: 010119 - PRINT DATE: 110118

 www.facebook.com/tpicorporation

 [@tpicorporation](https://twitter.com/tpicorporation)

LIGHTS

Table Of Contents & Limited Warranty

CATEGORY	Page
INDUSTRIAL CIRCULATORS	
24" & 30" Assembled Maximum Duty	2
24" & 30" Unassembled Maximum Duty	3
24" & 30" Heavy Duty Yellow	4
24" & 30" Assembled Heads & Mounts	5
24" & 30" Unassembled	6
20" Circulators & Components	7
20" 24" & 30" Specialty Heads	8
COMMERCIAL CIRCULATORS	
20", 24" & 30" Commercial Circulators	9
20", 24" & 30" Commercial Oscillators	9
COMMERCIAL BLOWERS	
36" 42" & 48" Belt Drive Portable	10
30" & 36" Direct Drive Portable	10
INDUSTRIAL BLOWERS	
30" 36" & 42" Direct Drive Portable	11
48" Direct Drive Portable	11
36" 42" & 48" Belt Drive Portable	12
30" 36" & 42" Direct Drive Suspension	13
36" 42" & 48" Belt Drive Suspension	13
Heavy Duty Direct Drive	14
Heavy Duty Permanent Mount Direct Drive	15
24" & 30" Mini	16
Heavy Duty Square Belt Drive Portable	16
WORKSTATION FANS	
Industrial Floor	17
Corrosion Resistant Industrial Floor	17
Industrial Mounted	18
Commercial Floor	18
Oscillating Office	18
Wall Mounted With Pivoting Arm	19
Low Velocity "Special Application"	19
EVAPORATIVE COOLERS	
36" & 48" Hazardous Location	20
16" 24" 36" & 48" Portable	20-21
Replacement Media Pads	21
MISTING FANS	
18" Portable Self Contained	22

CATEGORY	Page
CEILING FANS	
Industrial Ceiling Fans	22
EXHAUST FANS & GUARDS	
Shutter Mounted Direct Drive	23
Guard Mounted Direct Drive	24
Venturi Mounted Direct Drive	25
Commercial - (Fans & Shutters)	26
Industrial Direct Drive	27
Industrial Belt Drive	28
Heavy Duty Direct Drive	29
Heavy Duty Belt Drive	30
Cabinet Exhaust Fans With Shutters	31
Accessories / Heavy Duty Shutters	32
Cabinet Accessories / Guards	33
Cabinet Exhaust Fan Package Options	34
Weather Hood	34
ROOF VENTILATORS	
Insulated Roof Curbs	35
Belt Drive Hooded Roof Ventilator	36
Direct Drive Roof Ventilator	37
Belt Drive Roof Ventilator	38
TUBEAXIAL DUCT FAN	
Direct Drive & Guards	39
Belt Drive	40
ATTIC FANS	
Roof Domes, Gable Fans, Attic Fans	41
INDUSTRIAL LIGHT PRODUCTS	
Portable Utility Lights	42-43
Heavy Duty Portable Utility Lights	44
Commercial Duty Portable Utility Lights	44
Loading Dock Lights	45
Loading Dock Light Performance Testing	45
Loading Dock - Fully Assembled, Standard	46
Ceiling Mounted Incandescent Flex Arm	46
Lighthouse Accessories	46
Modular Loading Dock Lights / Heavy Duty	47
Loading Dock Arm Fan	47
Machine Tool Lights	48-49
Illuminated Fluorescent Magnifiers	49
PRODUCT INDEX	50-54

TPI Corporation provides a limited warranty of materials and workmanship for a period of (i) ten (10) years for elements in 2900 Series baseboard heaters, (ii) two (2) years for Thermostats and Controls, (iii) five (5) years on HD and HDH series fans, (iv) three (3) years on UHP and IHP series fans, (v) and twelve (12) months for all other products, with the warranty period commencing on the original date of purchase. The TPI warranty is limited to materials manufactured and work performed by TPI Corporation, and does not include damage or failure caused by acts of God, abuse, misuse, connected to or placed on other than rated voltage, abnormal usage, faulty installation, failure to follow suggested maintenance procedures enclosed with the product, improper maintenance or any repairs other than those provided by an authorized TPI Corporation service center. For the name of your nearest authorized TPI Corporation service center, please write to TPI Corporation, P.O. Box 4973, Johnson City, Tennessee, 37602 or call 1-800-682-3398.

During the warranty period, TPI Corporation will, at its sole option, repair or replace any defective parts or products returned, freight prepaid, to the TPI Corporation factory or such other location as TPI Corporation may designate. No parts or products will be accepted for repair or replacement without prior authorization from TPI Corporation and a return merchandise authority (RMA) number issued by TPI Corporation. Returned products must be packaged carefully and TPI Corporation shall not be responsible for damage in transit. When returning parts, the owner must provide the model number of the product and nature of difficulty being experienced.

This warranty does not obligate TPI Corporation to bear the cost of labor in replacing any assembly, unit or component part thereof, nor does TPI Corporation assume any liability for secondary charges, expenses for installing or removal, freight or damages. There will be charges rendered for product repairs made after the warranty period has expired. Proof of purchase, including date, must accompany request for in-warranty service. This warranty gives you specific legal rights and you may have other rights, which may vary, from state to state.

Except for the limited warranty provided in the foregoing paragraph, all parts and products sold by TPI Corporation are sold 'as is', 'where is', and without any other warranty of any kind or nature, whether express, implied, or statutory and including, without limitation, any implied warranty of specific performance or merchantability.

Under no circumstances, even with respect to claims covered by the foregoing warranty, will TPI Corporation be responsible for any incidental, consequential, special, or punitive damages of any kind or nature arising from or related to the parts or products sold by TPI Corporation.

In any event, TPI Corporation's maximum liability shall not in any case exceed the purchase price for the part or product claimed to be defective.

You hereby expressly agree to waive any and all rights to a trial by jury with respect to any product manufactured or supplied by TPI Corporation.

Ventilation Products Warranty Coverage	
Series HD or HDH fans	5 Years
Series UHP or IHP fans	3 Years
All other ventilation products	1 Year

RETURN POLICY:

Requests for returns of non-defective standard stock units may incur testing and repackaging charges if units are not in like new condition. Requests for returns of build to order items are subject to cancellation charges prior to shipment and up to a 100% restocking charge after shipment. This also applies to any standard model with factory installed control options or other custom features. Changes made to custom products during production may incur labor charges. Please consult factory for details on any return or change order

TPI COMMERCIAL CIRCULATORS STATEMENT:

TPI Commercial circulators have been developed to equal the imported circulators that are sold by big-box retail stores and some catalogers. Because these circulators do not have totally enclosed motors, they should be used in clean, dry commercial applications - such as schools, shops, offices, and warehouses.

Note: Prices subject to change without notice.

TPI Industrial Assembled Maximum Duty Circulators

Features

- Easy access hinged guard
- 18" drop down, 2-Speed switch
- Cord options are shown below
- Steel hub/spider aluminum paddle blades
- Powder coated steel guards
- Meets OSHA standards
- 5 year limited warranty
- Made in U.S.A. with domestic and foreign components.

DIMENSIONS		
24"	27" Diameter x 14.5" Depth	
30"	33.5" Diameter x 14.5" Depth	

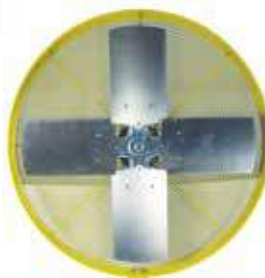

Closed (Front)

Motor Specifications

- 2-Speed
- 1-Phase, 120V
- Permanent split capacitor
- Frame size: 48
- 1/2 HP
- Ball bearing
- Totally enclosed, permanently lubricated
- 1/2" Shaft



Open (Front)



WARNING: This product can expose you to chemicals including nickel which is known to the State of California to cause cancer, and chromium, which is known to the State of California to cause birth defects and/or reproductive harm. For more information go to www.P65Warnings.ca.gov.

Pedestal Specifications

- Pedestal pole adjusts the center of the fan from 48 to 67 inches.
- Pedestal steel dome base is 27" in diameter and has 5 bolts.

Factory Assembled and Tested Fan Heads, Mounts, and Wheel Kits



HDM-C CEILING MOUNT

Note: 1 1/2" pipe piece required for assembly

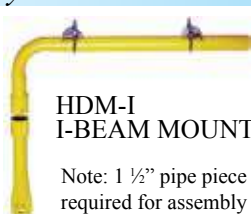

HDM-I I-BEAM MOUNT

Note: 1 1/2" pipe piece required for assembly



HDM-W WALL MOUNT



OPTIONAL WHEEL KIT

Standard Models

ASSEMBLED FAN HEAD		COLOR	BLADE SIZE	HP	CFM* / RPM		VELOCITY PROFILE	AMPS	WT. (LBS)	HEAD LIST
MFG CATALOG NUMBER	MFG MODEL NUMBER				HIGH	LOW	CFM / Area Sq Ft			
08744402	HDH 24-JR	Yellow	24"	1/2	5600 / 1100	4900 / 800	7500 / 260	3.5	44	743
08744602	HDH 30-JR	Yellow	30"		6800 / 1100	6000 / 800	8000 / 270	4	48	764
08745002	HDH 24-GJR	Gray	24"		5600 / 1100	4900 / 800	7500 / 260	3.5	44	743
08745102	HDH 30-GJR	Gray	30"		6800 / 1100	6000 / 800	8000 / 270	4	48	764

*Measured 2 feet from face of fan

Accessories

MFG CATALOG NUMBER	MFG MODEL NUMBER	COLOR	DESCRIPTION	WT. (LBS)	LIST
07960902	HDM-P	Yellow	Heavy Duty Pedestal Mount	34	227
07961002	HDM-W	Yellow	Heavy Duty Wall Mount	3	90
07961102	HDM-I	Yellow	Heavy Duty I-Beam Mount	9	172
07961202	HDM-C	Yellow	Heavy Duty Ceiling Mount	3	99
07961802	ACM-P	Gray	Pedestal Mount	34	214
07961902	ACM-W	Gray	Wall Mount	3	83
07962002	ACM-I	Gray	I-Beam Mount	9	162
07962102	ACM-C	Gray	Ceiling Mount	3	107
07962202	ACM-S	Gray	Suspension Mount	2	73
08747202	RS 06-EC	Yellow	6' Extension cord used with drop down power switch	1	26
08747302	RS 09-EC	Yellow	9' Extension cord used with drop down power switch	1.5	28
08747402	RS 12-EC	Yellow	12' Extension cord used with drop down power switch	2	30
08772502	RS 15-EC	Yellow	15' Extension cord used with drop down power switch	2.5	33
08747502	SCK-12	---	12' Safety cable with clamps	.5	28
08747602	R1-MOT	Yellow	1/2 HP motor with remote switch	1	214
08681802	ACM-PM	Standard Black	Pole Mount	5	118
08681302	ACM-WK	Standard Black	Optional Wheel Kit	4	100

TPI Industrial Unassembled Maximum Duty Circulators

Features

- Easy access hinged guard
- 18" drop down, 2-Speed switch
- Cord options are shown below
- Steel hub/spider aluminum paddle blades
- Coated steel guards
- Meets OSHA standards
- Made in U.S.A. with domestic and foreign components.

DIMENSIONS	
24"	27" Diameter x 14.5" Depth
30"	33.5" Diameter x 14.5" Depth



Closed (Front)



Open (Front)

Motor Specifications

- 2-Speed
- 1-Phase, 120V
- Ball bearing
- Frame size: 48
- Totally enclosed
- Permanent split capacitor
- Permanently lubricated
- 1/2" Shaft

WARNING: This product can expose you to chemicals including nickel which is known to the State of California to cause cancer, and chromium, which is known to the State of California to cause birth defects and/or reproductive harm. For more information go to www.P65Warnings.ca.gov.



Note: 1/2 HP fans come with 3 paddle blades.

Product Specifications

- Pedestal pole adjusts the center of the fan from 48 to 67 inches.
- Pedestal steel dome base is 27" in diameter and has 5 bolts.



TPI Industrial Mounts



Note: Motor, blades, guard, and mount are packed and shipped in a single UPS-able carton.

Standard Models

FAN TYPE		HIGH PERFORMANCE			MAX AMPS
MOTOR	HP	1/3			
	SPEEDS	2			
CFM (HIGH/LOW) RPM (HIGH/LOW)	24"	4300 / 3900 1100 / 800		2.8	
	30"	5400 / 4700 1100 / 800		3.0	
COLOR		GRAY			
POLE ADJUSTMENT		52" to 78"			
WARRANTY		3 YEARS			
SIZE	TYPE of MOUNT	MFG CATALOG NUMBER	MFG MODEL NUMBER	WT. (LBS)	LIST
24"	Pedestal Mount	08745202	UHP 24-PJR	75	808
	Wall Mount	08745402	UHP 24-WJR	45	681
	I-Beam Mount	08745602	UHP 24-IJR	50	756
	Ceiling Mount	08745802	UHP 24-CJR	45	691
	Suspension Mount	08746002	UHP 24-SJR	43	676
30"	Pedestal Mount	08745302	UHP 30-PJR	78	826
	Wall Mount	08745502	UHP 30-WJR	48	704
	I-Beam Mount	08745702	UHP 30-IJR	53	777
	Ceiling Mount	08745902	UHP 30-CJR	48	712
	Suspension Mount	08746102	UHP 30-SJR	46	697

Accessories

MFG CATALOG NUMBER	MFG MODEL NUMBER	COLOR	DESCRIPTION	WT. (LBS)	LIST
08747202	RS 06-EC	Yellow	6' Extension cord used with drop down power switch	1	26
08747302	RS 09-EC	Yellow	9' Extension cord used with drop down power switch	1.5	28
08747402	RS 12-EC	Yellow	12' Extension cord used with drop down power switch	2	30
08772502	RS 15-EC	Yellow	15' Extension cord used with drop down power switch	2.5	33
08747502	SCK-12	----	12' Safety cable with clamps	.5	28
08747702	R2-MOT	Gray	1/3 HP motor with drop down remote switch	1	208

TPI Industrial Heavy Duty Yellow Air Circulator

Features

- Pull chain switch
- Cord-SJT type 3 conductor, 12' long
- Steel hub/spider aluminum paddle blades
- Powder coated steel guards
- Meets OSHA standards
- 5 year limited warranty
- Made in U.S.A. with domestic and foreign components.

DIMENSIONS	
24"	27" Diameter x 14.5" Depth
30"	33.5" Diameter x 14.5" Depth

Motor Specifications

- 2-Speed
- 1 Phase, 120V
- Permanent split capacitor
- Frame size: 48
- 1/2 HP
- Ball bearing
- Totally enclosed, permanently lubricated
- 1/2" Shaft

HDH-30 FAN HEAD
WITH HDM-P
PEDESTAL MOUNT

⚠ WARNING: This product can expose you to chemicals including nickel which is known to the State of California to cause cancer, and chromium, which is known to the State of California to cause birth defects and/or reproductive harm. For more information go to www.P65Warnings.ca.gov.



Pedestal Specifications

- Pedestal pole adjusts the center of the fan from 48 to 67 inches.
- Pedestal steel dome base is 27" in. diameter and has 5 bolts.

Factory Assembled and Tested Fan Heads, Mounts, and Wheel Kits



HDM-C
CEILING MOUNT

Note: 1 1/2" pipe piece required for assembly



HDM-I
I-BEAM MOUNT

Note: 1 1/2" pipe piece required for assembly



HDM-W
WALL MOUNT



OPTIONAL
WHEEL KIT

Standard Models

SIZE	CFM* / RPM		VELOCITY PROFILE	AMPS HIGH	FAN TYPE	FAN HEAD		MOUNT		WT. (LBS)	HEAD LIST	MOUNT LIST
	HIGH	LOW	CFM / Area Sq Ft			MFG CATALOG NUMBER	MFG MODEL NUMBER	MFG CATALOG NUMBER	MFG MODEL NUMBER			
24"	5600 / 1100	4900 / 800	7500 / 260	3.5	Fan Head	07960702	HDH 24	-----	-----	44	680	-----
					Pedestal Fan		HDH 24	07960902	HDM-P	78	680	227
					Wall Mount Fan		HDH 24	07961002	HDM-W	47	680	90
					I-Beam Mount Fan		HDH 24	07961102	HDM-I	53	680	172
					Ceiling Mount Fan		HDH 24	07961202	HDM-C	47	680	99
30"	6800 / 1100	6000 / 800	8000 / 270	4	Fan Head	07960802	HDH 30	-----	-----	48	696	-----
					Pedestal Fan		HDH 30	07960902	HDM-P	82	696	227
					Wall Mount Fan		HDH 30	07961002	HDM-W	51	696	90
					I-Beam Mount Fan		HDH 30	07961102	HDM-I	57	696	172
					Ceiling Mount Fan		HDH 30	07961202	HDM-C	51	696	99
Optional Wheel Kit							08681302	ACM-WK	4	----	100	

*Measured 2 feet from face of fan

TPI Industrial Assembled Circulator Heads and Mounts

Features

- Pull chain switch
- SJT type 3 conductor, 12' long cord
- Steel hub/spider aluminum paddle blades
- Coated steel guards
- Meets OSHA standards
- Made in U.S.A. with domestic and foreign components.

DIMENSIONS	
24"	27" Diameter x 14.5" Depth
30"	33.5" Diameter x 14.5" Depth



ACH 30

Motor Specifications

- 2-Speed
- 1 Phase, 120V
- Ball bearing
- Frame size: 48
- Totally enclosed
- Permanent split capacitor
- Permanently lubricated
- 1/2" Shaft



Product Specifications

- Oscillating model oscillates in a 90° arc or can be locked in a fixed position
- Metal gears in the oscillating mechanism allow the fan to operate at a maximum 30° downward tilt

WARNING: This product can expose you to chemicals including nickel which is known to the State of California to cause cancer, and chromium, which is known to the State of California to cause birth defects and/or reproductive harm. For more information go to www.P65Warnings.ca.gov.

Standard Models

H.P.	BLADE SIZE	MFG MODEL NUMBER	MFG CATALOG NUMBER	FAN HEAD TYPE	CFM*	VELOCITY PROFILE	RPM	AMPS	WT. (LBS)	LIST
						CFM / Area Sq Ft				
Industrial 1/4	24"	ACH 24	07961602	STATIONARY	3800 / 3400	6000 / 240	1100 / 800	2.5	40	390
	30"	ACH 30	07961702		4300 / 3800	7200 / 250	1100 / 800	2.7	44	404
1 Year Warranty										
High Performance 1/3	24"	IHP 24-H	07989802	STATIONARY	4300 / 3900	6000 / 240	1100 / 800	2.8	40	498
	30"	IHP 30-H	07989902		5400 / 4700	7200 / 250	1100 / 800	3	44	521
3 Year Warranty										
Heavy Duty 1/2	24"	HDH 24-G	08539202	STATIONARY	5600 / 4900	7500 / 260	1100 / 800	3.5	44	652
	30"	HDH 30-G	08528602		6800 / 6000	8000 / 270	1100 / 800	4	48	674
5 Year Warranty										
Industrial Oscillating 1/4	20"	ACH 20-O	08684802	OSCILLATING	3000 / 2600	5000 / 200	1100 / 900	2.4	43	527
	24"	ACH 24-O	07963602		3800 / 3400	6000 / 240	1100 / 800	2.5	44	600
	30"	ACH 30-O	07963702		4300 / 3800	7200 / 250	1100 / 800	2.7	48	622
1 Year Warranty										

*Measured 2 feet from face of fan

TPI offers six factory assembled and tested fan mounts that can be used with any of the non-oscillating TPI Industrial heads.

Industrial Mounts

MOUNT	MFG MODEL NUMBER	MFG CATALOG NUMBER	WT. (LBS)	LIST
Pedestal	ACM-P	07961802	34	214
Wall Mount	ACM-W	07961902	3	83
I-Beam Mount	ACM-I	07962002	9	162
Ceiling Mount	ACM-C	07962102	3	107
Suspension Mount	ACM-S	07962202	2	73
Pole Mount	ACM-PM	08681802	5	118
Optional Wheel Kit	ACM-WK	08681302	4	100

TPI Industrial Unassembled Circulators

Features

- Pull chain switch
- SJT type 3 conductor, 12' long cord
- Steel hub/spider aluminum paddle blades
- Coated steel guards
- Meets OSHA standards
- Motor, blades, guard, and mount are packed and shipped in a single UPS-able carton.
- Made in U.S.A. with domestic and foreign components.



WALL MOUNT



PEDESTAL

Motor Specifications

- 2-speed
- 1-Phase, 120V
- Ball bearing
- Frame size: 48
- Totally enclosed
- Permanent split capacitor
- Permanently lubricated
- 1/2" Shaft

DIMENSIONS	
24"	27" Diameter x 14.5" Depth
30"	33.5" Diameter x 14.5" Depth

WARNING: This product can expose you to chemicals including nickel which is known to the State of California to cause cancer, and chromium, which is known to the State of California to cause birth defects and/or reproductive harm. For more information go to www.P65Warnings.ca.gov.

Product Specifications

- Oscillating model oscillates in a 90° arc or can be locked in a fixed position
- Metal gears in the oscillating mechanism allow the fan to operate at a maximum 30° downward tilt

Standard Models

FAN TYPE		HIGH PERFORMANCE				MAX AMPS	STANDARD INDUSTRIAL				MAX AMPS	OSCILLATING				MAX AMPS
MOTOR	HP	1/3				2.8	1/4				2.5	1/4				2.5
	SPEEDS	2					2					2				
CFM / RPM	24"	4300 / 3900		3.0	2.8	3800 / 3400		2.7	2.5	3800 / 3400		2.7	1100 / 800		2.5	
	30"	5400 / 4700				4300 / 3800				4300 / 3800			1100 / 800			
COLOR		GRAY				GRAY				GRAY						
POLE ADJUSTMENT		52" to 78"				52" to 78"				52" to 78"						
WARRANTY		3 YEARS				1 YEAR				1 YEAR						
SIZE	TYPE of MOUNT	MFG CATALOG NUMBER	MFG MODEL NUMBER	WT. (LBS)	LIST	MFG CATALOG NUMBER	MFG MODEL NUMBER	WT. (LBS)	LIST	MFG CATALOG NUMBER	MFG MODEL NUMBER	WT. (LBS)	LIST			
24"	Pedestal Mount	07990002	UHP 24-P	75	674	07962302	ACU 24-P	75	502	07964002	ACU 24-PO	79	761			
	Wall Mount	07990202	UHP 24-W	45	550	07962402	ACU 24-W	45	418	07964102	ACU 24-WO	49	637			
30"	Pedestal Mount	07990102	UHP 30-P	73	696	07962802	ACU 30-P	73	516	07964202	ACU 30-PO	82	777			
	Wall Mount	07990602	UHP 30-W	48	570	07962902	ACU 30-W	48	433	07964302	ACU 30-WO	52	652			

TPI Industrial 20" Circulators



PEDESTAL



WALL MOUNT

⚠ WARNING: This product can expose you to chemicals including nickel which is known to the State of California to cause cancer, and chromium, which is known to the State of California to cause birth defects and/or reproductive harm. For more information go to www.P65Warnings.ca.gov.

Features

- Pull chain switch
- SJT type 3 conductor, 12' long cord
- Steel hub/spider aluminum paddle blades
- Coated steel guards
- Meets OSHA standards
- 1 Year limited warranty
- Made in U.S.A. with domestic and foreign components.

DIMENSIONS
22" Diameter x 14.5" Depth

Motor Specifications

- 2-Speed
- 1-Phase, 120V
- Ball bearing
- Frame size: 48
- 1/4 HP
- Permanent split capacitor
- Totally enclosed, permanently lubricated
- 1/2" Shaft

Standard Models

MFG CATALOG NUMBER	MFG MODEL NUMBER	STYLE	MOUNT TYPE	CFM / RPM	AMPS (HIGH)	WT. (LBS.)	LIST
08681402	ACU 20-P	Unassembled all components and mount in one box	Pedestal Mount	3000 / 2600 1100 / 900	2.4	72	485
08681602	ACU 20-PO		Pedestal Mount			76	512
08681502	ACU 20-W		Wall Mount			42	394
08681702	ACU 20-WO		Wall Mount			46	410
08684702	ACH 20	Assembled Fan Head	None - use with any TPI "ACM" or "CACM" Mount			39	349

TPI Industrial Circulator Components

Mounts

TYPE	MFG CATALOG NUMBER	MFG MODEL NUMBER	LIST
YELLOW MOUNTS			
PEDESTAL POLE & BASE	07960902	HDM-P	227
WALL MOUNT	07961002	HDM-W	90
I-BEAM MOUNT	07961102	HDM-I	172
CEILING MOUNT	07961202	HDM-C	99
GRAY MOUNTS			
PEDESTAL POLE & BASE	07961802	ACM-P	214
WALL MOUNT	07961902	ACM-W	83
I-BEAM MOUNT	07962002	ACM-I	162
CEILING MOUNT	07962102	ACM-C	107
SUSPENSION MOUNT	07962202	ACM-S	73
POLE MOUNT	08681802	ACM-PM	118
WHEEL KIT	08681302	ACM-WK	100
FDA WHITE MOUNTS FOR USE WITH WASHDOWN FAN HEADS IN FOOD SERVICE APPLICATIONS			
PEDESTAL POLE & BASE	08682502	WACM-P	211
WALL MOUNT	08682602	WACM-W	83

TPI Industrial Specialty Circulator Heads



*Listing applies to 277V models only.

WARNING: This product can expose you to chemicals including nickel which is known to the State of California to cause cancer, and chromium, which is known to the State of California to cause birth defects and/or reproductive harm. For more information go to www.P65Warnings.ca.gov.

Features

- No cord-junction box provided for hard wiring
- Steel hub/spider aluminum paddle blades
- Coated steel guards
- Meets OSHA standards
- 1 year limited warranty
- Made in U.S.A. with domestic and foreign components.

Motor Specifications

- All 1 Speed (except 277V which is 2 Speed)
- Totally enclosed, permanently lubricated
- Ball bearing

Standard Models

GENERAL DESCRIPTION	MFG MODEL NUMBER	MFG CATALOG NUMBER	SIZE	CFM*		VELOCITY PROFILE CFM / Area Sq Ft	MOTOR			AMPS (HIGH)					WT. (LBS)	LIST
				HIGH	LOW		HP	RPM	VOLTS	120v 1 ph	240v 1 ph	277v 1 ph	240v 3 ph	480v 3 ph		
Hazardous Location Class I Group D Class II Group F & G Unassembled Head	ACH 24-EX1	08551902	24"	4300		6000 / 240	1/4	1725	120 or 240 1-phase	5	2.6	----	----	----	66	1207
	ACH 30-EX1	08552002	30"	5400		7200 / 250									69	1309
	ACH 24-EX3	08552102	24"	4300		6000 / 240									66	1287
	ACH 30-EX3	08552202	30"	5400		7200 / 250									69	1409
240V / 480V 3-Phase Unassembled Head	ACH 24-TE3	08552302	24"	4300		6000 / 240	1/4	1725	240 or 480 3-phase	----	----	1.4	0.7	45	832	
	ACH 30-TE3	08552402	30"	5400		7200 / 250								48	851	
277 Volt Assembled Head	IHP 24-H-277	08541302	24"	4300	3900	6000 / 240	1/3	1125	277 1-phase	----	----	1	----	----	40	585
	IHP 30-H-277	08542202	30"	5400	4700	7200 / 250									44	622
Wash down rated 120V / 240V 1-Phase Assembled Head	IHP 20-H-WD	08721902	20"	3200		5200 / 220	1/3	1725	120 or 240 1-phase	4.5	2.2	----	----	----	46	1112
	IHP 24-H-WD	08541802	24"	4300		6000 / 240									48	1152
	IHP 30-H-WD	08541902	30"	5400		7200 / 250									52	1191

*Measured 2 feet from face of fan

Note: Wash down rated fan heads have heavy zinc coated guards - Use FDA white coated mounts shown on page 7 for food service applications.

Product Specifications

- Pedestal pole adjusts the center of fan from 48" to 67" and bolts to 27" diameter steel dome base with 5 bolts
- I-beam mount & ceiling mount require 1 1/2" or longer pipe nipple for assembly (not supplied)
- Pole mount attaches to 4", 6", or 8" with U-bolts (not supplied)

Standard Models

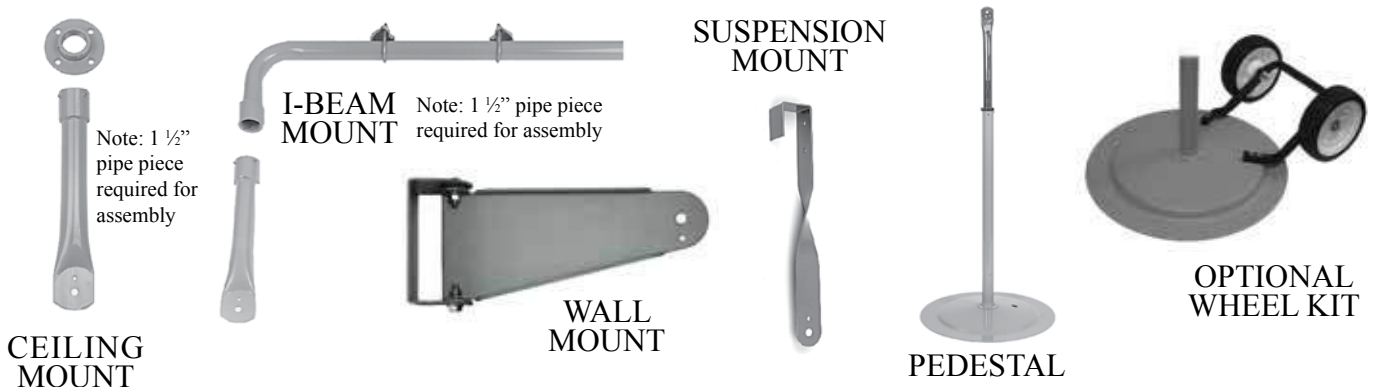

CIRCULATOR MOUNT	MFG MODEL NUMBER	MFG CATALOG NUMBER	WT. (LBS)	LIST
Pedestal	ACM-P	07961802	34	214
Wall Mount	ACM-W	07961902	3	83
I-Beam Mount	ACM-I	07962002	9	162
Ceiling Mount	ACM-C	07962102	3	107
Suspension Mount	ACM-S	07962202	2	73
Pole Mount	ACM-PM	08681802	5	118
Optional Wheel Kit	ACM-WK	08681302	4	100

TPI Commercial Circulators



These circulators should be used in clean and dry commercial applications - such as schools, shops, offices or warehouses.

Commercial Circulator

Motor, blades, guards, and mount are packed and shipped in a single UPS-able carton.

Features

- Pull chain switch.
- SJT type 3 conductor, 9' long cord.
- Coated steel guards with retaining clips.
- Steel hub/spider aluminum paddle blades.
- Pole adjusts center of fan from 43" to 60".
- Meets OSHA standards.
- 1 Year limited warranty.
- Imported to TPI specifications

Motor Specifications

- 1-Phase
- 1/4 HP, 1/3 HP on HD Models
- Ball bearing
- Open ventilated
- 120V
- 2 or 3-Speed
- Permanently lubricated
- Permanent split capacitor



Standard Models

MFG CATALOG NUMBER	MFG MODEL NUMBER	SIZE	HP	TYPE	MOUNT TYPE	CFM*			VELOCITY PROFILE	AMPS (HIGH)	WT. (LBS)	LIST		
						HIGH	MED	LOW	CFM / Area Sq Ft					
08778002	CACU 20-P	20"	1/10	Standard	Pedestal Mount	1780	1600	1420	3300 / 125	1.4	52	281		
08778102	CACU 20-W				Wall Mount						48	254		
08706202	CACU 24-P	24"	1/4		Pedestal Mount	3400	3100	2800	5400 / 220	2.3	63	414		
08706402	CACU 24-W				Wall Mount						43	354		
08697402	CACU 30-P	30"			1/3	Pedestal Mount	4200	3800	3500	6700 / 240	2.4	66	457	
08706302	CACU 30-W					Wall Mount						46	367	
08761702	CACU 30-P-HD	30"		1/3		Heavy Duty	Pedestal Mount	5000	4600	4200	7000 / 250	3.60	56	531

*Measured 2 feet from face of fan

Note: Stocked models may differ in appearance from photograph

TPI Commercial Oscillating Fans

Commercial wall mount and pedestal fans now available from TPI.

Units imported to TPI specifications.

Standard Models

⚠ WARNING: This product can expose you to chemicals including nickel which is known to the State of California to cause cancer, and chromium, which is known to the State of California to cause birth defects and/or reproductive harm. For more information go to www.P65Warnings.ca.gov.



MFG CATALOG NUMBER	MFG MODEL NUMBER	SIZE	HP	TYPE	MOUNT TYPE	CFM*			VELOCITY PROFILE	AMPS			WT. (LBS)	LIST		
						HIGH	MED	LOW	CFM / Area Sq Ft	HIGH	MED	LOW				
08748902	CACU 24-PO	24"	1/4	Standard	Pedestal Mount	3200	3000	2800	5100 / 230	1.45	1.15	1.1	68	489		
08749102	CACU 24-WO				Wall Mount								48	418		
08749002	CACU 30-PO	30"			Pedestal Mount	4200	3800	3500	6700 / 250	2.0	1.8	1.6	70	513		
08749202	CACU 30-WO				Wall Mount								51	454		
08761802	CACU 30-PO-HD	30"			1/3	Heavy Duty	Pedestal Mount	5000	4600	4200	7000 / 250	3.60	3.02	2.94	64	657

*Measured 2 feet from face of fan

Note: Stocked models may differ in appearance from photograph - sizes are nominal.

36", 42", & 48" TPI Commercial Belt Drive Portable Blowers



WARNING: This product can expose you to chemicals including nickel which is known to the State of California to cause cancer, and chromium, which is known to the State of California to cause birth defects and/or reproductive harm. For more information go to www.P65Warnings.ca.gov.



Features

- Rocker switch
- SJT type cord - 3 conductor - 8' long
- Aluminum blade
- Spiral wire front and rear guards
- Powder coated 20 gauge steel housing
- 5" rubber wheels
- Meets OSHA standards / 1 Year limited warranty
- Imported to TPI specifications

Motor Specification

- 2-Speed
- 120V
- Ball bearing
- 1-Phase
- ODP type
- Permanently lubricated

Standard Models

MFG CATALOG NUMBER	MFG MODEL NUMBER	MOTOR HP	CFM*		VELOCITY PROFILE	MAX AMPS	WT. (LBS)	LIST
			HIGH	LOW	CFM / Area Sq Ft			
08734702	CPB 36-B	1/3	5,400	4,600	8600 / 300	4.8	82	739
08706602	CPB 42-B	1/2	7,600	6,700	12000 / 320	6.5	93	948
08722702	CPB 48-B	3/4	8,800	7,700	14000 / 500	9.0	129	1282

*Measured 2 feet from face of fan
 Note: Photograph is a representation of stocked models. Actual model may vary in appearance.

24", 30", & 36" TPI Commercial Direct Drive Portable Blowers



SWIVEL

WARNING: This product can expose you to chemicals including nickel which is known to the State of California to cause cancer, and chromium, which is known to the State of California to cause birth defects and/or reproductive harm. For more information go to www.P65Warnings.ca.gov.

CPBS 30-D



FLOOR

CPB 36-D



Features

- Rocker switch
- SJT type cord - 3 conductor - 6' long
- Spiral wire front and rear guards
- Powder coated 20 gauge steel housing
- 5" rubber wheels
- Meets OSHA standards
- 1 Year limited warranty
- Imported to TPI specifications

Motor Specification

- 2-Speed
- 120 Volt, 1/3HP
- Ball bearing
- 1-Phase
- Open ventilated
- Permanently lubricated

Standard Models

MFG CATALOG NUMBER	MFG MODEL NUMBER	TYPE	CFM*		VELOCITY PROFILE	MAX AMPS	CORD LENGTH	SWITCH	BLADES	WT. (LBS)	LIST
			HIGH	LOW	CFM / Area Sq Ft						
08753502	CPB 30-D	Standard / Floor	4,400	3,800	6700 / 250	3.6	6'	ROCKER	ALUMINUM	52	548
08710302	CPBS 30-D	Standard / Swivel	4,400	3,800	6700 / 250	3.6	6'	ROCKER	ALUMINUM	60	623
08722602	CPB 36-D	Standard / Floor	5,400	4,600	8500 / 300	3.6	10'	ROTARY	STEEL	70	678
08770102	CPBS 24-DHV	High Velocity / Swivel	3,400	2,900	5400 / 240	2.4	9'	ROTARY	ALUMINUM	38	275

*Measured 2 feet from face of fan
 Note: Photograph is a representation of stocked models. Actual model may vary slightly in appearance.

30", 36", & 42" TPI Industrial Direct Drive Portable Blowers



STANDARD MODEL

⚠ WARNING: This product can expose you to chemicals including nickel which is known to the State of California to cause cancer, and chromium, which is known to the State of California to cause birth defects and/or reproductive harm. For more information go to www.P65Warnings.ca.gov.



SWIVEL MODEL



Features

- Comes in sizes 30", 36", & 42"
- Rocker switch
- SJT type 3 conductor, 12' long cord
- Aluminum, 3 paddle blade
- Spiral, wire front and rear guards
- Corrosion and dent proof high density polyethylene housing
- 36" & 42" swivel model rotates 130° in 12 1/2° increments and locks in place with a steel locking pin
- Meets OSHA standards
- 1 Year limited warranty
- Made in U.S.A.

Motor Specifications

- 120V, 1-Phase
- 36"-1/3HP 42"-1/2HP
- Ball bearing
- Permanent split capacitor
- 2-Speed on 36" model
- 1-Speed on 42" model
- Permanently lubricated
- Totally enclosed

Standard Models

MFG CATALOG NUMBER	MFG MODEL NUMBER	FAN		WHEEL SIZE	MOTOR HP	CFM* / RPM		VELOCITY PROFILE CFM / Area Sq Ft	AMPS (HIGH)	WT. (LBS.)	LIST
		SIZE	TYPE			HIGH	LOW				
08743902	PB 30-D	30"	STANDARD	8"	1/4	4400	3800	7200 / 250	2.5	65	769
08744002	PBS 30-D	30"	SWIVEL	10"							
08730402	PB 36-D	36"	STANDARD	8"	1/3	6500 / 1040	5400 / 950	11500 / 320	5.5	82	846
08730502	PBS 36-D	36"	SWIVEL	10"							
08730702	PB 42-D	42"	STANDARD	10"	1/2	9,000 / 825		15000 / 340	6.0	102	1189
08730802	PBS 42-D	42"	SWIVEL	10"							

*Measured 2 feet from face of fan

Note: Photograph is a representation of stocked models. Actual model may vary slightly in appearance.

48" TPI Industrial Direct Drive Portable Blowers



Features

- Corrosion and dent proof high density polyethylene housing
- Rocker switch
- SJT type 3 conductor, 12' long cord
- Steel, 2 paddle blade
- Spiral, wire front and rear guards
- 10" wheels
- Swivel model rotates 130° in 12 1/2° increments and locks in place with a steel locking pin
- Meets OSHA standards
- 1 Year limited warranty
- Made in U.S.A.

Motor Specifications

- 1-Phase
- 3/4 HP
- Ball bearing
- Permanent split capacitor
- 120V
- 1-Speed
- Permanently lubricated
- Totally enclosed

⚠ WARNING: This product can expose you to chemicals including nickel which is known to the State of California to cause cancer, and chromium, which is known to the State of California to cause birth defects and/or reproductive harm. For more information go to www.P65Warnings.ca.gov.

Features

MFG CATALOG NUMBER	MFG MODEL NUMBER	SIZE	FAN TYPE	MOTOR HP	CFM* \ RPM	VELOCITY PROFILE CFM / Area Sq Ft	AMPS (HIGH)	DIMENSIONS			WT. (LBS)	LIST
								"H"	"D"	"W"		
07997802	PB 48-D-OP	48"	STANDARD	3/4	11,800 / 825	14000 / 360	10.3	58.5	29	55.5	117	1716
07998002	PBS 48-D-OP	48"	SWIVEL	3/4	11,800 / 825	14000 / 360	10.3	----	----	----	142	1959

*Measured 2 feet from face of fan

Note: Photograph is a representation of stocked models. Actual model may vary slightly in appearance.

36", 42", & 48" TPI Industrial Belt Drive Portable Blowers

Features

- Comes in sizes 36", 42", and 48"
- Rocker switch on 120V, Single Phase models
- SJT type 3 conductor, 12' long cord on 120V, Single Phase models / no cord on dual voltage models
- Aluminum, 4 paddle blade (48" PB / PBS have steel blade)
- Spiral, wire front and rear guards
- Corrosion and dent proof high density polyethylene housing
- 8" wheels (36" model), 10" wheels (42" & 48" models)
- Swivel model rotates 130° in 12 1/2° increments and locks in place with a steel locking pin
- External junction boxes on dual voltage models allow units to be wired for either voltage without removing guards
- Hazardous location models have explosion proof motors, metal housings, and external junction boxes rated for Class I, Group D and Class II, Groups E, F, & G
- Meets OSHA standards
- 1 year limited warranty
- Made in U.S.A.



STANDARD MODEL

⚠ WARNING: This product can expose you to chemicals including nickel which is known to the State of California to cause cancer, and chromium, which is known to the State of California to cause birth defects and/or reproductive harm. For more information go to www.P65Warnings.ca.gov.



SWIVEL MODEL



CORDWRAP INCLUDED WITH STANDARD MODEL

Motor Specifications

- 1-Speed
- Ball bearing
- Permanently lubricated

Standard Models

MOTOR LISTING	SIZE	MOTOR				CFM**	VELOCITY PROFILE	STANDARD MODEL				SWIVEL MODEL			
		TYPE	HP	RPM	AMPS		CFM / Area Sq Ft	MFG CATALOG NUMBER	MFG MODEL NUMBER	WT. (LBS)	LIST	MFG CATALOG NUMBER	MFG MODEL NUMBER	WT. (LBS)	LIST
	36"	120 V 1 PH ODP	1/2	500	8.0	6,900	14000 / 360	07964702	PB 36-B	120	1257	07965002	PBS 36-B	145	1481
	42"		3/4	430	11.0	10,600	17500 / 420	07964802	PB 42-B	135	1436	07965102	PBS 42-B	160	1703
	48"		1	390	15.0	14,400	23500 / 550	07964902	PB 48-B	155	1611	07965202	PBS 48-B	180	1919
	36"	240/480 V 3 PH ODP	1/2	500	2.3 / 1.1	6,900	14000 / 360	08508602	PB 36-B-3	127	1695	08509202	PBS 36-B-3	152	1998
	42"		3/4	430	3.3 / 1.5	10,600	17500 / 420	08508702	PB 42-B-3	143	1901	08509302	PBS 42-B-3	168	2370
	48"		1	390	3.4 / 1.7	14,400	23500 / 550	08508802	PB 48-B-3	164	2163	08509402	PBS 48-B-3	189	2494
----	36"	120/240 V 1 PH EXP	1/2	500	7.8 / 3.9	6,900	14000 / 360	08508902	PB 36-B-HL*	135	2555	08509502	PBS 36-B-HL	160	2820
	42"		3/4	430	10.8 / 5.4	10,600	17500 / 420	08509002	PB 42-B-HL*	150	2689	08509602	PBS 42-B-HL	175	3213
	48"		1	390	13.2 / 6.6	14,400	23500 / 550	08509102	PB 48-B-HL*	173	3153	08509702	PBS 48-B-HL	198	3478

**Measured 2 feet from face of fan *Models have no listing.
 Note: Products listed in this section are custom built and subject to 100% cancellation/restocking charges.
 Note: Photograph is a representation of stocked models. Actual model may vary slightly in appearance.

TPI Industrial Direct Drive Suspension Blowers



WARNING: This product can expose you to chemicals including nickel which is known to the State of California to cause cancer, and chromium, which is known to the State of California to cause birth defects and/or reproductive harm. For more information go to www.P65Warnings.ca.gov.

Features

- On-Off rocker switch
- SJT type 3 conductor, 12' long cord
- Aluminum blade
- Powder coated spiral wire front and rear guards
- Corrosion and dent proof high density polyethylene housing
- Spiral wire front and rear guards
- Meets OSHA standards
- 1 year limited warranty
- Made in U.S.A.

Motor Specifications

- 120V, 1-Phase
- Ball bearing
- Permanent split capacitor
- 2-Speed on 30" & 36" model
- 1-Speed on 42" model
- Permanently lubricated

Standard Models

SIZE	MOTOR HP	MFG CATALOG NUMBER	MFG MODEL NUMBER	CFM*		VELOCITY PROFILE	RPM HIGH	AMPS HIGH	WT. (LBS)	LIST
				HIGH	LOW	CFM / Area Sq Ft				
30"	1/4	08748802	SB 30-D	4,400	3,800	7200 / 250	1050	2.5	58	730
36"	1/3	08730602	SB 36-D	6,500	5,400	11500 / 320	1050	5.6	70	846
42"	1/2	08730902	SB 42-D	9,000		15000 / 340	825	7.9	99	1190

*Measured 2 feet from face of fan

TPI Industrial Belt Drive Suspension Blowers



WARNING: This product can expose you to chemicals including nickel which is known to the State of California to cause cancer, and chromium, which is known to the State of California to cause birth defects and/or reproductive harm. For more information go to www.P65Warnings.ca.gov.

Features

- On-Off rocker switch on 120V, 1-Phase models
- SJT type 3 conductor, 12' long cord on 120V, 1 phase models
- No cord on dual voltage models
- Aluminum blade
- Powder coated front and rear guards
- Corrosion and dent proof high density polyethylene housing
- Powder coated spiral wire front and rear guards
- Meets OSHA standards
- 1 year limited warranty
- Mounting chain not included.
- Made in U.S.A.

Motor Specifications

- 120V, 1-Phase
- Ball bearing
- Permanent split capacitor
- 2-Speed on 30" & 36" model
- 1-Speed on 42" model
- Permanently lubricated

External junction boxes on dual voltage models allow units to be wired for either voltage without removing guards.

Hazardous Location models have explosion proof motors and external junction boxes rated for Class I, Group D, & Class II, Groups E, F & G., (Metal housing and no switch.)

Standard Models

MFG CATALOG NUMBER	MFG MODEL NUMBER	SIZE	MOTOR		CFM**	VELOCITY PROFILE	RPM	AMPS	WT. (LBS)	LIST
			TYPE	HP		CFM / Area Sq Ft				
07965502	SB 36-B	36"	115 V, 1 PH, ODP	1/2	6,900	14000 / 360	500	8	120	1211
07965602	SB 42-B	42"		3/4	10,600	17500 / 420	430	11	135	1380
07965702	SB 48-B	48"		1	14,400	23500 / 550	390	15	155	1550
08509802	SB 36-B-3	36"	230 / 460 V, 3 PH, ODP	1/2	6,900	14000 / 360	500	2.3 / 1.1	127	1616
08509902	SB 42-B-3	42"		3/4	10,600	17500 / 420	430	3.3 / 1.5	143	1956
08510002	SB 48-B-3	48"		1	14,400	23500 / 550	390	3.8 / 1.9	164	2058
08510102	SB 36-B-HL*	36"	115 / 230 V, 1 PH, EXP	1/2	6,900	14000 / 360	500	7.8 / 3.9	135	2555
08510202	SB 42-B-HL*	42"		3/4	10,600	17500 / 420	430	10.8 / 5.4	150	2905
08510302	SB 48-B-HL*	48"		1	14,400	23500 / 550	390	13.2 / 6.6	173	3153

Note: Products listed in this section are custom built and subject to 100% cancellation/restocking charges.
 Note: Photograph is a representation of stocked models. Actual model may vary slightly in appearance.

*Models have no listing.
 **Measured 2 feet from face of fan

TPI Industrial Heavy Duty Direct Drive Blowers

WARNING: This product can expose you to chemicals including nickel which is known to the State of California to cause cancer, and chromium, which is known to the State of California to cause birth defects and/or reproductive harm. For more information go to www.P65Warnings.ca.gov.



LOW STAND



MEDIUM STAND



HIGH STAND

Features

- Totally enclosed and explosion proof motors
- Explosion proof motors are Class 1, Div 1, Group D and Class 2, Div 1, Groups F & G
- Cast Aluminum props
- 14 gauge steel body and stand
- Acid resistant coating available
- Baked enamel coating
- 360° Swivel on high and medium stand units
- Meets federal OSHA requirements
- 1 year limited warranty

NOTE:

Single phase motors are field convertible 115V / 230V
 Three phase motors are field convertible 230V / 460V
 Motors are set to lower voltage at the factory unless a request is made at time of order to set to the higher voltage

Standard Models

SIZE	MFG MODEL NUMBER	HP	RPM	CFM	DB's @ 10'	WT. (LBS)			LIST											
						STAND			TEC		EXP		TEC		EXP		TEC		EXP	
						LOW	MED	HIGH	1PH	3PH	1PH	3PH	1PH	3PH	1PH	3PH	1PH	3PH	1PH	3PH
MODEL NUMBER SUFFIXES									-L	-L-3	-L	-L-3	-M	-M-3	-M	-M-3	-H	-H-3	-H	-H-3
18"	MCD18-1/4	1/4	1725	3050	74	103	145	210	3039	3026	3498	3572	3747	3733	4198	4283	4088	4075	4550	9208
	MCD18-1/3	1/3	1725	3450	76	105	150	215	3143	3169	3740	3894	3848	3870	4445	4607	4192	4213	4794	8677
	MCD18-1	1	1725	4600	77	117	165	230	3546	3415	4205	4283	4259	4120	4905	4990	4600	4465	5254	5333
24"	MCD24-1/4	1/4	1725	5200	80	115	165	230	3110	3099	3559	3647	3908	3902	4354	4445	4186	3998	4633	4724
	MCD24-1/3	1/3	1140	5300	74	126	175	250	3609	3647	4588	4640	4405	4445	5383	5438	4684	4544	5663	5714
	MCD24-1/2	1/2	1725	6000	80	120	170	240	3370	3383	4071	3998	4167	4181	4866	4794	4445	4283	5144	5073
	MCD24-3/4	3/4	1140	6900	74	140	190	260	4303	3894	4878	4745	5100	4697	5677	5541	5377	4794	5954	5818
	MCD24-1	1	1725	7400	82	130	180	250	3656	3525	4308	4386	4452	4322	5105	5183	4730	4419	5383	5461
	MCD24-1 1/2	1.5	1725	8200	84	137	190	255	3863	3694	5709	4692	4659	4496	6505	5488	4938	4594	6784	5765
	MCD24-3	3	1725	10500	87	160	210	270	----	4032	----	5100	----	4828	----	5903	----	4931	----	6174
30"	MCD30-1/3	1/3	1140	6900	80	150	205	260	3959	3998	4938	4990	4833	4872	5813	5870	5183	5222	6155	6214
	MCD30-1/2	1/2	1725	8900	86	141	195	250	3725	3740	4426	4354	4607	4619	5305	5237	4952	4963	5649	5578
	MCD30-3/4	3/4	1140	10400	80	210	260	320	4557	4154	5126	4995	5429	5029	6007	5875	5774	5371	6349	6221
	MCD30-1	1	1140	11200	81	200	260	310	5461	4381	6513	5183	6343	5260	7392	6057	6685	5604	7735	6401
	MCD30-1 1/2	1.5	1725	12000	92	200	250	310	4205	4037	6051	5035	5079	4920	6933	5915	5422	5260	7275	6259
	MCD30-2	2	1140	14000	84	225	270	330	----	4684	----	5831	----	5565	----	6712	----	5909	----	7056
	MCD30-3	3	1725	16000	94	220	265	325	----	4289	----	5359	----	5170	----	6238	----	5516	----	6577
36"	MCD36-1	1	1140	13000	82	250	320	375	6168	5087	7218	5884	7250	6174	8305	6973	7478	6395	8526	7192
	MCD36-1 1/2	1.5	1725	14850	88	250	320	375	4878	4711	6724	5709	5962	5792	7807	6790	6187	6016	8034	7018
	MCD36-2	2	1140	17500	82	255	325	380	----	5204	----	6355	----	6291	----	7438	----	6513	----	7665
	MCD36-3	3	1725	18500	90	260	330	390	----	4970	----	6038	----	6051	----	7126	----	6277	----	7347
	MCD36-5	5	1725	23000	94	260	330	390	----	5055	----	6227	----	6135	----	7308	----	6355	----	7529
42"	MCD42-2	2	1140	19500	85	315	415	565	----	5974	----	7126	----	7126	----	8274	----	7581	----	8733
	MCD42-5	5	1725	27000	98	320	420	570	----	5818	----	6997	----	6973	----	8143	----	7431	----	8610
48"	MCD48-5	5	1140	32000	92	500	620	710	----	7892	----	9828	----	9161	----	11097	----	9969	----	11907
	MCD48-7 1/2	7.5	1140	37000	105	625	745	835	----	9161	----	12368	----	10432	----	13637	----	11240	----	14441
	MCD48-10	10	1140	41000	105	682	800	890	----	10721	----	13579	----	11990	----	14841	----	12796	----	15651
60"	MCD60-3	3	690	35000	87	690	855	965	----	16819	----	----	----	19214	----	----	----	19764	----	----
	MCD60-5	5	690	45000	87	730	895	1005	----	18915	----	----	----	21305	----	----	----	21863	----	----
	MCD60-7 1/2	7.5	870	47000	90	945	1110	1220	----	15852	----	----	----	18242	----	----	----	18793	----	----
	MCD60-10	10	870	57200	91	1035	1200	1310	----	19731	----	----	----	22123	----	----	----	22679	----	----
	MCD60-15	15	870	60750	92	1080	1245	1355	----	25808	----	----	----	28197	----	----	----	28753	----	----

Manual Starter Switches

MFG MODEL NUMBER		H.P. RATING	LIST PRICE	
1 PH	3 PH		TEC	
			1 PH	3 PH
SW-1/4	SW-1/4-3	1/4-1/3	587	1399
SW-1/2	SW-1/2-3	1/2-3/4	587	1399
SW-1	SW-1-3	1	587	1399
SW-1 1/2	SW-1 1/2-3	1.5	1375	1399
----	SW-2-3	2	----	1399
----	SW-3-3	3	----	1399
----	SW-5-3	5	----	1399
----	SW-7 1/2-3	7.5	----	1327

Polyolifin Casters

MFG MODEL NUMBER	FAN SIZE	WHEEL SIZE	WT. (LBS)	LIST
CAS - 18	18" - 30"	4"	10	562
CAS - 48	36" - 48"	5"	14	791

(FOR LOW & MEDIUM STAND)
 4 CASTERS - 2 LOCKING

Note: Products listed in this section are custom built and subject to 100% cancellation/restocking charges.

TPI Industrial Heavy Duty Permanent Mount Direct Drive Blowers



1-WAY SWIVEL



2-WAY SWIVEL

⚠ WARNING: This product can expose you to chemicals including nickel which is known to the State of California to cause cancer, and chromium, which is known to the State of California to cause birth defects and/or reproductive harm. For more information go to www.P65Warnings.ca.gov.

Features

- Front and rear spiral guards
- Explosion proof motors are Class 1, Div 1, Group D and Class 2, Div 1, Groups F & G
- Cast aluminum props
- 14 gauge steel body and stand
- Meets federal OSHA requirements
- 1 year limited warranty

NOTE:

Single Phase motors are field convertible 115V / 230V
 Three Phase motors are field convertible 230V / 460V
 Motors are set to lower voltage at the factory unless a request is made at time of order to set to the higher voltage

Standard Models

BLADE SIZE	MFG MODEL NUMBER	HP	RPM	CFM	DB'S @ 10'	WT. (LBS)		LIST PRICE							
								1-WAY SWIVEL				2-WAY SWIVEL			
						TEC		EXP		TEC		EXP			
						1PH	3PH	1PH	3PH	1PH	3PH	1PH	3PH		
								-T	-T-3	-T	-T-3	-S	-S-3	-S	-S-3
18"	MCD18-1/4	1/4	1725	3050	74	130	140	4032	4019	4483	4562	5059	5049	5521	5599
	MCD18-1/3	1/3	1725	3450	76	135	145	4135	4154	4731	4886	5165	5183	5765	5924
	MCD18-1	1	1725	4600	77	145	155	4535	4405	5190	5275	5571	5438	6227	6305
24"	MCD24-1/4	1/4	1725	5200	80	145	155	4154	4135	4600	4692	5237	5217	5677	5765
	MCD24-1/3	1/3	1140	5300	74	155	165	4652	4692	5631	5682	5727	5765	6707	6757
	MCD24-1/2	1/2	1725	6000	80	150	160	4413	4426	5112	5042	5488	5508	6187	6117
	MCD24-3/4	3/4	1140	6900	74	170	180	5345	4943	5924	5786	6422	6019	6997	6867
	MCD24-1	1	1725	7400	82	160	170	4697	4567	5353	5429	5774	5644	6428	6505
	MCD24-1 1/2	1.5	1725	8200	84	165	175	4898	4738	6750	5735	5979	5813	7826	6812
	MCD24-3	3	1725	10500	87	190	200	----	5073	----	6142	----	6149	----	7218
30"	MCD30-1/3	1/3	1140	6900	80	180	190	5042	5079	6019	6071	6234	6272	7205	7263
	MCD30-1/2	1/2	1725	8900	86	170	180	4808	4821	5516	5438	6002	6012	6700	6628
	MCD30-3/4	3/4	1140	10400	80	240	250	5638	5229	6214	6077	6824	6422	7400	7270
	MCD30-1	1	1140	11200	81	230	240	6544	5461	7600	6266	7735	6654	8786	7451
	MCD30-1 1/2	1.5	1725	12000	92	230	240	5288	5120	7134	6117	6479	6311	8324	7308
	MCD30-2	2	1140	14000	84	255	265	----	5765	----	6912	----	6959	----	8104
	MCD30-3	3	1725	16000	94	250	260	----	5371	----	6447	----	6556	----	7631
36"	MCD36-1	1	1140	13000	82	295	305	7516	6428	8566	7224	8991	7904	10042	8706
	MCD36-1 1/2	1.5	1725	14850	88	295	305	6214	6051	8068	7048	7746	7529	9542	8526
	MCD36-2	2	1140	17500	82	300	310	----	6544	----	7697	----	8029	----	9175
	MCD36-3	3	1725	18500	90	315	325	----	6311	----	7381	----	7787	----	8857
	MCD36-5	5	1725	23000	94	305	315	----	6388	----	7568	----	7873	----	9044

Exhaust Ventilation Guide

Minute air change chart for Commercial and Industrial Applications.

CFM Required for Ventilation = $\frac{\text{Building Cubic Feet}}{\text{Minutes Per Air Change}}$

Place	Typical	Range
Assembly	(6)	2-10
Auditoriums	(6)	1-20
Bakeries	(2)	1-3
Banks	(6)	3-10
Bars	(4)	2-5
Barns	(15)	10-20
Boiler Rooms	(2)	1-3
Bowling Alley	(3)	1-5
Cafeteria	(4)	3-5
Churches	(6)	2-10
Classrooms	(6)	4-8
Compressor Rooms	(2)	1-3
Dance Halls	(6)	2-10
Dairies	(4)	2-5
Dormitories	(6)	4-8
Dry Cleaning Plant	(3)	1-5

Place	Typical	Range
Engine Rooms	(3)	1-5
Factories	(7)	4-10
Foundries	(5)	2-8
Garages	(7)	4-10
Generating Plants	(4)	2-5
Glass Plants	(2)	1-3
Gymnasiums	(6)	2-10
Hallways	(8)	4-12
Kitchens (Comm.)	(3)	1-5
Laboratories	(3)	1-5
Libraries	(4)	2-5
Laundries	(2)	1-3
Locker Rooms	(6)	2-10
Machine Shops	(4)	2-5
Markets	(6)	2-10

Place	Typical	Range
Mills	(4)	2-5
Packing Houses	(4)	3-5
Plants	(7)	4-10
Plating Plants	(4)	2-5
Print Shops	(7)	4-10
Restaurants	(6)	2-10
Rest Rooms	(7)	4-10
Schools	(7)	4-10
Stores	(7)	4-10
Theaters	(6)	4-8
Transformer Rooms	(3)	1-5
Turbine Rooms	(4)	2-5
Waiting Rooms	(12)	10-15
Warehouses	(7)	4-10
Welding Rooms	(3)	1-4

Note: Products listed in this section are custom built and subject to 100% cancellation/restocking charges.

TPI Industrial Mini-Blowers



FLOOR MODEL



MBM-W (optional wall/ceiling mount)

⚠ WARNING: This product can expose you to chemicals including nickel which is known to the State of California to cause cancer, and chromium, which is known to the State of California to cause birth defects and/or reproductive harm. For more information go to www.P65Warnings.ca.gov.



YOKE MOUNTED MODEL

TOTALLY ENCLOSED MOTOR ALLOWS MINI-BLOWER TO BE USED IN DIRTY OR DUSTY ENVIRONMENTS.

AVAILABLE AS FLOOR MODEL OR YOKE MOUNTED MODEL THAT CAN BE DIRECTLY BOLTED TO ANY SURFACE OR USED WITH OPTIONAL WALL/CEILING MOUNT.

Features

- Floor models have rotary switch
- Yoke mounted models have pull chain switch
- SJT type 3 conductor, 10' long cord
- Aluminum blade
- Spiral, wire front and rear guards
- Corrosion and dent proof high density polyethylene housing
- Meets OSHA standards
- 1 year limited warranty
- Made in U.S.A. with domestic and foreign components.

Motor Specifications

- 1-Phase
- 1/4 HP
- Ball bearing
- Totally enclosed
- 120V
- 2-Speed
- Permanently lubricated
- Permanent split capacitor

Standard Models

MFG CATALOG NUMBER	MFG MODEL NUMBER	FAN		CFM* / RPM		VELOCITY PROFILE	DIMENSIONS			AMPS (High)	WT. (LBS)	LIST
		TYPE	SIZE	HIGH	LOW	CFM / Area Sq Ft	"H"	"W"	"D"			
08743502	MB 24-DF	FLOOR STYLE	24"	3300 / 1140	2900 / 1070	5200 / 240	29 1/2"	28 1/2"	14 1/4"	2.2	52	730
08743602	MB 24-DY	YOKE STYLE		29"	28 1/2"		14 1/4"	52	730			
08743702	MB 30-DF	FLOOR STYLE	30"	4400 / 1040	3900 / 730	7000 / 250	38 1/2"	37 1/2"	14 1/2"	2.5	58	807
08743802	MB 30-DY	YOKE STYLE		38"	37 1/2"		14 1/2"	58	807			
07989002	MBM-W	OPTIONAL WALL/CEILING MOUNT FOR YOKE STYLE MINI-BLOWER									4	148

*Measured 2 feet from face of fan

TPI Industrial Heavy Duty Square Belt Drive Portable Blowers

4" CASTERS



⚠ WARNING: This product can expose you to chemicals including nickel which is known to the State of California to cause cancer, and chromium, which is known to the State of California to cause birth defects and/or reproductive harm. For more information go to www.P65Warnings.ca.gov.

Features

- On-Off rocker switch
- SJT type 3 conductor, 12' long cord
- Aluminum blade
- Permanently lubricated bearings on blade drive shaft
- Powder coated front and rear guards
- Powder coated 20 gauge venturi
- 18 gauge galvanized steel housing
- Meets OSHA standards / 1 Year limited warranty
- Made in U.S.A.

Motor Specifications

- 1-Phase
- Ball bearing
- Drip proof motor
- 120V
- 1-Speed
- Permanently lubricated
- 1/2" Shaft

Standard Models

SIZE	MFG CATALOG NUMBER	MFG MODEL NUMBER	MOTOR			CFM*	VELOCITY PROFILE	DIMENSIONS			WT. (LBS)	LIST
			HP	RPM	AMPS		CFM / Area Sq Ft	"H"	"W"	"D"		
36"	08683602	PCBT 36-B	1/2	500	8.0	6,900	14,000 / 360	48 1/4"	28 1/4"	22 1/2"	120	1863
42"	08683702	PCBT 42-B	3/4	430	11.0	10,600	17,500 / 420	56 1/2"	34 1/4"	22 1/2"	140	2421
48"	08683802	PCBT 48-B	1	390	15.0	14,400	23,500 / 550	62 1/2"	40 1/4"	18 1/2"	185	2943

*Measured 2 feet from face of fan

Industrial Workstation Floor Fans

Features



HIGH STAND



WARNING: This product can expose you to chemicals including nickel which is known to the State of California to cause cancer, and chromium, which is known to the State of California to cause birth defects and/or reproductive harm. For more information go to www.P65Warnings.ca.gov.



FLOOR MODEL

- Rotary switch
- Head tilts 360°
- Coated steel guards
- SJT type 3 conductor, 10' long cord
- Steel hub/spider aluminum paddle blades
- Meets OSHA standards
- 1 Year limited warranty
- Imported to TPI specifications.

Motor Specifications

- Sleeve bearing
- Totally enclosed
- 1-Phase, 120V
- 3-Speed
- Permanently lubricated
- Frame size: 42
- 5/16" Shaft

Standard Models

SIZE	MFG CATALOG NUMBER	MFG MODEL NUMBER	FAN TYPE	MOTOR HP	CFM** / RPM			VELOCITY PROFILE CFM / Area Sq Ft	DIMENSIONS			MAX AMPS	WT. (LBS)	LIST
					HIGH	MED	LOW		"H"	"W"	"D"			
12"	07986102	F-12-TE	FLOOR MODEL	1/12	900 / 1590	800 / 1380	700 / 1080	1400 / 50	15 1/4"	14 1/2"	9 1/2"	1.1	13	164
18"	07972902	F-18-TE		1/8	1800 / 1660	1500 / 1550	1300 / 1370	2900 / 125	20 1/2"	20 1/2"	10 1/2"	1.5	20	206
24"	08528502	F-24-TE		1/8	2100 / 1634	1900 / 1484	1600 / 1200	3500 / 150	26"	26"	10 1/2"	2.4	23	248
24"	08775402	F-24-TE-HV		1/4	3800 / 1100	3600 / 950	3400 / 800	6000 / 240	26"	26"	10 1/2"	2.7	25	281
18"	07973002	F-18H-TE*	HIGH STAND	1/8	1800 / 1660	1500 / 1550	1300 / 1370	2900 / 125	53"	25"	27"	2.2	27	310
24"	08540602	F-24H-TE*		1/8	2100 / 1634	1900 / 1484	1600 / 1200	3500 / 150	53"	30"	27"	2.4	30	347

**Measured 2 feet from face of fan

*Made in U.S.A. with domestic and foreign components.

Corrosion Resistant Industrial Workstation Fans

Features



HIGH STAND



WALL/CEILING MODEL



FLOOR MODEL

WARNING: This product can expose you to chemicals including nickel which is known to the State of California to cause cancer, and chromium, which is known to the State of California to cause birth defects and/or reproductive harm. For more information go to www.P65Warnings.ca.gov.



- Pull chain switch
- Head tilts 360°
- FDA white coated steel guards
- SJTW type 3 conductor, 10' long cord
- Steel hub/spider aluminum paddle blades
- Corrosion resistant motor and switch
- Meets OSHA standards / 1 Year limited warranty
- Made in U.S.A. with domestic and foreign components.

Motor Specifications

- Sleeve bearing
- Totally enclosed
- 1-Phase, 120V
- 3-Speed
- Permanently lubricated
- Frame size: 42
- 1/2" Shaft
- Sealed electrical enclosure

Standard Models

SIZE	MFG CATALOG NUMBER	MFG MODEL NUMBER	FAN TYPE	MOTOR HP	CFM* / RPM			VELOCITY PROFILE CFM / Area Sq Ft	DIMENSIONS			MAX AMPS	WT. (LBS)	LIST
					HIGH	MED	LOW		"H"	"W"	"D"			
18"	08763202	F-18-CR	FLOOR MODEL	1/8	1800 / 1660	1500 / 1550	1300 / 1370	2900 / 125	20 1/2"	20 1/2"	10 1/2"	1.5	20	431
24"	08763502	F-24-CR		1/8	2100 / 1634	1900 / 1484	1600 / 1200	3500 / 150	26"	26"	10 1/2"	2.4	23	492
18"	08763302	F-18H-CR	HIGH STAND	1/8	1800 / 1660	1500 / 1550	1300 / 1370	2900 / 125	53"	25"	27"	2.2	27	572
24"	08763602	F-24H-CR		1/8	2100 / 1634	1900 / 1484	1600 / 1200	3500 / 150	53"	30"	27"	2.4	30	617
18"	08763102	U-18-CR	WALL/CEILING MODEL	1/8	1800 / 1660	1500 / 1550	1300 / 1370	2900 / 125	21 1/2"	20 1/2"	10 1/2"	2.2	20	431
24"	08763402	U-24-CR		1/8	2100 / 1634	1900 / 1484	1600 / 1200	3500 / 150	27"	26"	10 1/2"	2.4	23	492

*Measured 2 feet from face of fan

Industrial Mounted Workstation Fans

Features



WARNING: This product can expose you to chemicals including nickel which is known to the State of California to cause cancer, and chromium, which is known to the State of California to cause birth defects and/or reproductive harm. For more information go to www.P65Warnings.ca.gov.

- Pull chain switch
- Head rotates 360° vertically and horizontally
- Coated steel guards
- SJT type 3 conductor, 10' long cord
- Steel hub/spider aluminum paddle blades
- Meets OSHA standards / 1 Year limited warranty
- Imported to TPI specifications



FAN SIZE	DIMENSIONS		
	"H"	"W"	"D"
12"	15 1/4"	14 1/2"	9 1/2"
18"	21 1/2"	20 1/2"	10 1/2"
24"	27"	26"	10 1/2"

Motor Specifications

- Sleeve bearing
- Totally enclosed, permanently lubricated
- Frame size: 42
- 3-Speed
- 1-Phase, 120V
- 5/16" Shaft

Standard Models

Pipe Mount Adaptor

FAN SIZE	MFG CATALOG NUMBER	MFG MODEL NUMBER	MOTOR HP	CFM* / RPM			VELOCITY PROFILE	MAX AMPS	WT. (LBS)	LIST	PIPE DIAMETER	MFG CATALOG NUMBER	MFG MODEL NUMBER	LIST
				HIGH	MED	LOW	CFM / Area Sq Ft							
12"	07986002	U-12-TE	1/12	900 / 1590	800 / 1380	700 / 1080	1400 / 50	1.1	13	172	1"	08512402	PM-1	58
18"	07972802	U-18-TE	1/8	1800 / 1660	1500 / 1550	1300 / 1370	2900 / 125	2.2	20	212	1 1/2"	08512502	PM-1.5	64
24"	08540702	U-24-TE	1/8	2100 / 1634	1900 / 1484	1600 / 1200	3500 / 150	2.4	23	238	2"	08512602	PM-2	70
24"	08775502	U-24-TE-HV	1/4	3800 / 1100	3600 / 950	3400 / 800	6000 / 240	2.7	25	254	2 1/2"	08512702	PM-2.5	76
											3"	08512802	PM-3	83

*Measured 2 feet from face of fan

Note: Mount with one bolt or lag screw to walls, ceilings, work benches, machines or any surface.

TPI Commercial Floor Fans

Features



CF-20



WARNING: This product can expose you to chemicals including nickel which is known to the State of California to cause cancer, and chromium, which is known to the State of California to cause birth defects and/or reproductive harm. For more information go to www.P65Warnings.ca.gov.

- Rotary switch
- SJT type cord - 3 conductor - 7' long
- Aluminum blade
- Coated steel guards with retaining clips
- Meets OSHA standards / 1 Year limited warranty
- Imported to TPI specifications

Motor Specification

- 3-Speed
- 120V
- Sleeve bearing
- 1-Phase
- Open ventilated
- Permanently lubricated

Standard Models

MFG CATALOG NUMBER	MFG MODEL NUMBER	SIZE	TYPE	MOTOR HP	CFM			MAX AMPS	WT. (LBS)	LIST
					HIGH	MED	LOW			
08723002	CF-12	12"	FLOOR	1/12	1050	875	750	0.6	10	96
08723102	CF-18	18"	FLOOR	1/5	1600	1480	1380	1.4	16	119
08706502	CF-20	20"	FLOOR	1/5	1725	1600	1480	1.9	18	164

Units should be used in clean, dry, commercial applications.

Note: Photograph is a representation of stocked models. Actual model may vary in appearance.

Workstation Oscillating Office Fans

Features



DESK FAN

STAND FAN



WARNING: This product can expose you to chemicals including nickel which is known to the State of California to cause cancer, and chromium, which is known to the State of California to cause birth defects and/or reproductive harm. For more information go to www.P65Warnings.ca.gov.

- 3-speed oscillating fans with push button controls
- 3 conductor SPT cord & plug
- White powder coated wire mesh guards
- White plastic housing and blade
- Stand fan extends to 40" height
- Meets OSHA standards / 1 Year limited warranty
- Imported to TPI specifications

Standard Models

SIZE	MFG CATALOG NUMBER	MFG MODEL NUMBER	FAN TYPE	SPEEDS	CFM HIGH	AMPS HIGH	WT. (LBS)	LIST
12"	08513002	ODF-12	DESK	3	860	0.4	5.4	82
16"	08513102	ODF-16	DESK	3	1530	0.5	8.5	96
16"	08513202	OSF-16	STAND	3	1530	0.5	15.5	121

Workstation Wall Mount Fan With Pivoting Arm

18" HIGH VELOCITY FAN MOUNTED ON 24", 40", or 60" PIVOTING ARMS



WARNING: This product can expose you to chemicals including nickel which is known to the State of California to cause cancer, and chromium, which is known to the State of California to cause birth defects and/or reproductive harm. For more information go to www.P65Warnings.ca.gov.

Mounting Arm Features

- 1 1/2" square, 14 gauge, steel tubing
- 3" x 5" x 3/16" mounting plate attaches with (4) 3/8" bolts
- 5' long, 18/3 SJTW conductor cord and NEMA 5-15 grounded plug
- Dual electrical outlets embedded in arm to allow connection of modular fan and optional light
- Made in U.S.A. with domestic and foreign components.



Modular Fan Features

- 18" high velocity circulator, with 3 speed, 1/8 HP, 115V, 1-Phase permanently lubricated, totally enclosed, PSC motor
- Modular fan plugs into electrical outlet on arm
- Coated steel guards / Aluminum blades
- Meets OSHA standards / 1 year limited warranty

Use on loading docks to cool off workers entering hot truck trailers.

Use at factory workstations to cool off people or the machines.

Standard Models

MFG CATALOG NUMBER	MFG MODEL NUMBER	FAN SIZE	ARM LENGTH	FAN CFM*			VELOCITY PROFILE	MAX AMPS	WT. (LBS)	LIST
				HIGH	MED	LOW	CFM / Area Sq Ft			
08009102	24-LDF-TE	18"	24"	1800	1500	1300	2900 / 125	2.2	31	347
08009202	40-LDF-TE	18"	40"						38	432
08009302	60-LDF-TE	18"	60"						44	464

*Measured 2 feet from face of fan

Optional Modular Lights



DKL-INC mounted on 40-LDF-TE (above)

WARNING: This product can expose you to chemicals including nickel which is known to the State of California to cause cancer, and chromium, which is known to the State of California to cause birth defects and/or reproductive harm. For more information go to www.P65Warnings.ca.gov.



Light Features

- Plugs into embedded outlet in arm
- On/Off switch and wire guard included
- Bulb included with DKL-QH and DKL-FL
- Made in U.S.A. with domestic and foreign components.

Standard Models

MFG CATALOG NUMBER	MFG MODEL NUMBER	LIGHT HEAD TYPE	MAX WATTS	MAX LUMENS	AVE. BULB LIFE (HRS)	WT. (LBS)	LIST
04465602	DKL-INC	Incandescent	300	3,700	2,000	5	89
04465702	DKL-QH	Quartz Halogen	500	11,000	2,000	6	133
04843302	DKL-FL	Fluorescent	55	3,000	10,000	7	206
04708602	DKL-LED	LED	12	960	50,000	5	303

Low Velocity "Special Application" Workstation Fan



WALL MOUNT

WARNING: This product can expose you to chemicals including nickel which is known to the State of California to cause cancer, and chromium, which is known to the State of California to cause birth defects and/or reproductive harm. For more information go to www.P65Warnings.ca.gov.

Features

- 12" all metal, gray powder coated fan that can be wall, ceiling or bench mounted
- Direct wire electrical connection
- Toggle switch
- Fan head tilts 90° in horizontal and vertical plane
- Meets OSHA standards / 1 year limited warranty
- Made in U.S.A. with domestic and foreign components



BENCH MOUNT



CEILING MOUNT

Standard Models

SIZE	MFG CATALOG NUMBER	MFG MODEL NUMBER	MOTOR HP	CFM* / RPM		VELOCITY PROFILE	AMPS HIGH	WT. (LBS)	LIST
				HIGH	LOW	CFM / Area Sq Ft			
12"	08708902	N-12	1/12	800 / 1350	600 / 1000	1200 / 40	0.6	12	361

*Measured 2 feet from face of fan

Portable Workstation Evaporative Cooler

Hazardous Location - Standard Models



FRONT Patented



CONTROL Patented

Hazardous Location - Specific Features

- All switches, motors, and cord connections are sealed to prevent sparking in combustible locations
- Shipped completely assembled, ready to use
- 120/240V operation
- Manufactured in U.S.A.
- Component Rating: Class 1A, Division D for Hazardous Location



WARNING: This product can expose you to chemicals including nickel which is known to the State of California to cause cancer, and chromium, which is known to the State of California to cause birth defects and/or reproductive harm. For more information go to www.P65Warnings.ca.gov.

Hazardous Location - Standard Models

MFG CATALOG NUMBER	MFG MODEL NUMBER	MOTOR HP	UNIT AMPS	CFM			EFFECTIVE SQ. FT.	INTERNAL WATER (Gallons)	DIMENSIONS H x W x D (Inches)	WT. (LBS)	LIST
				HIGH	MED	LOW					
08748302	EVAP36-HAZ	1/2	13.4	9600			2500	32	32 x 62 x 67	330	16016
08748502	EVAP48-HAZ	1	18	20000			4000	40	36 x 74 x 86	460	19382

Portable Evaporative Coolers



FRONT Patented



BACK Patented

Features

- Liquid level indicator with automatic pump shut off
- When pump is deenergized, red LED indicator light is on
- Heavy duty casters
- Variable speed motors
- Built in handles for easy moving
- Two inch drain for convenient lushing and cleaning



WARNING: This product can expose you to chemicals including nickel which is known to the State of California to cause cancer, and chromium, which is known to the State of California to cause birth defects and/or reproductive harm. For more information go to www.P65Warnings.ca.gov.



BACK
Patented



WARNING: This product can expose you to chemicals including nickel which is known to the State of California to cause cancer, and chromium, which is known to the State of California to cause birth defects and/or reproductive harm. For more information go to www.P65Warnings.ca.gov.



FRONT
Patented



Standard Models

MFG CATALOG NUMBER	MFG MODEL NUMBER	EFFECTIVE SQ. FT.	CFM	VELOCITY (MPH)	INTERNAL WATER (Gallons)	FAN BLADE (Inches)	UNIT AMPS	WT. (LBS)	SPEEDS	DIMENSIONS H x W x D (Inches)	LIST
08774102	EVAP16HD	1,125	4,500	29	50	16	8.3	152	Variable	60.8 x 41.8 x 24.5	3686
08774202	EVAP24HD	2,125	8,500	24	55	24	6.6	213	Variable	69.8 x 54.9 x 32.5	4820
08774302	EVAP36HD	3,125	12,500	25	60	36	9.3	267	Variable	77 x 67 x 34.5	5909
08774402	EVAP48HD	5,625	22,500	26	65	48	15.2	375	Variable	89.4 x 78.8 x 40.3	8142

Replacement Media Pads



WARNING: This product can expose you to chemicals including nickel which is known to the State of California to cause cancer, and chromium, which is known to the State of California to cause birth defects and/or reproductive harm. For more information go to www.P65Warnings.ca.gov.

MFG CATALOG NUMBER	MFG MODEL NUMBER	CORRESPONDING EVAP UNITS	LIST*
08775002	PADEVAP-Mini700	EVAP Mini-700	244
08774802	PADEVAP16HD	EVAP16HD	443
08774702	PADEVAP24HD	EVAP24HD	666
08774602	PADEVAP36HD	EVAP36HD	890
08774502	PADEVAP48HD	EVAP48HD	1112

*Pricing is for complete set

Portable 18" Self Contained Power Mister



SELF CONTAINED MISTING SYSTEM WITH WATER PUMPED FROM A 10 GALLON TANK OR VESSEL.

Features

- Toggle Switch - Pump on/off
- SJT type cord - 3 conductor - 18' long with GFCI plug
- 18" Aluminum blade
- Spiral front and rear wire guards
- Standard model - Low Pressure 85 PSI diaphragm pump
- HD model - Medium Pressure 125 PSI diaphragm pump
- Meets OSHA standards / 1 year limited warranty / Made in U.S.A.

Motor Specification

- 3-Speed, 1/10 HP
- Sleeve bearing
- Permanently lubricated
- 1-Phase, 120 Volt
- Totally enclosed
- Permanent split capacitor

WARNING: This product can expose you to chemicals including nickel which is known to the State of California to cause cancer, and chromium, which is known to the State of California to cause birth defects and/or reproductive harm. For more information go to www.P65Warnings.ca.gov.

Note: Tank lid not included.

Standard Models

MFG CATALOG NUMBER	MFG MODEL NUMBER	FAN SIZE	TYPE	MOTOR HP	CFM*	AMPS	WT. (LBS)	VELOCITY PROFILE	LIST
								CFM / Area Sq Ft	
08554702	PM-18S	18"	HAND CARRY	1/10	1900	1.1	30	3100 / 140	1236
08775702	PM-18S-HD								1292
08554902	PM-18C	18"	CART	1/10	1900	1.1	30		1571
08775602	PM-18C-HD								1628
08760702	NK-PM18	---	REPLACEMENT NOZZLE KIT				---		29

18" Fan & Pump Lid for 10gal. Tank

MFG CATALOG NUMBER	MFG MODEL NUMBER	WT. (LBS)	LIST
08555202	PM-18FO	28	1059
08775802	PM-18FO-HD	28	1115

*Measured 2 feet from face of fan

Industrial Ceiling Fans



Note: Photograph is a representation of stocked models. Actual model may vary in appearance.

WARNING: This product can expose you to chemicals including nickel which is known to the State of California to cause cancer, and chromium, which is known to the State of California to cause birth defects and/or reproductive harm. For more information go to www.P65Warnings.ca.gov.

Features

- All metal construction, white epoxy finish
- 24" down rod with safety cable
- Mounts to 3/8" diameter steel J-hook
- 18 pole (motor), 115V, 1-Phase, capacitor type, impedance protected motor with sealed ball bearings
- Imported to TPI specifications

Commercial Grade

- Assembly required
- 30" lead wires
- 1 year limited warranty

Industrial Grade

- Fully assembled except blade bolt down
- 3 conductor cord, 30" long with plug
- Permanently lubricated
- 3 year limited warranty

Heavy Duty Grade

- Fully assembled except blade bolt down
- 3 conductor cord, 30" long with plug
- Permanently lubricated
- 6 year limited warranty

Standard Models

GRADE	MFG CATALOG NUMBER	MFG MODEL NUMBER	TYPE	SIZE	VOLTS	CFM	RPM	AMPS	WT. (LBS)	LIST
Commercial	08529602	CHR-56*	Down Draft	56"	120	7000	320	0.6	15	201
Industrial	07979902	IHR-48	Down Draft	48"	120	5000	320	0.53	14	270
Industrial	07971502	IHR-56	Down Draft	56"	120	7000	310	0.6	15	284
Industrial	07980002	IHR-56R*	Reversible	56"	120	7000	310	0.55	14	289
Industrial	08008902	IHR-56-277V*	Down Draft	56"	277	7000	310	0.3	16	289
Water and Dust Resistant Models										
Heavy Duty	08540802	HDHR-56WR	Down Draft	56"	120	7000	320	1.1	17	399
Heavy Duty	08540902	HDHR-60WR	Down Draft	60"	120	7800	320	0.8	21	449

* 277 volt, commercial, and reversing models have lead wires instead of cordset. 36" down rod available for additional charge.

Solid State Controls (120 & 277V Models)

MFG CATALOG NUMBER	MFG MODEL NUMBER	VOLTS	MAX AMPS	VARIABLE CONTROL KNOB	REVERSING SWITCH	MAX # OF FANS	USE WITH CEILING FAN MODEL	LIST
07976302	KBWC-13K	120	3	YES; W/3" X 5" ALUMINUM PLATE (FITS 2" X 4" OPENING)	No	1-2	CHR-56, IHR-48/56, HDHR-56/60-WR	53
07976402	KBWC-15K	120	5			3-5	CHR-56, IHR-48/56, HDHR-56/60-WR	125
07994102	KBWC-110K	120	10			6-10	CHR-56, IHR-48/56, HDHR-56/60-WR	183
08666802	KBWC-15SK	120	5		Yes	3-5	IHR-56R	168
08526502	KBWC-310K	277	10		No	6-10	IHR-56-277V	351

Options

MFG CATALOG NUMBER	MFG MODEL NUMBER	TYPE	LIST
08512202	HR-GUARD	FOR 56" MODELS	1119
08504202	ADD SUFFIX; "X3"	36" DOWN ROD OPTION	+54 Adder

Shutter Mounted Direct Drive Exhaust Fans

Features

- Can be installed from inside wall
- Eliminates need for external framing and shutter
- Pull chain switch
- No Cord-Junction box provided for direct wiring
- Aluminum blade
- Steel spiral wire guards
- Made in U.S.A. with domestic and foreign components.
- See sizing chart on page 15

WARNING: This product can expose you to chemicals including nickel which is known to the State of California to cause cancer, and chromium, which is known to the State of California to cause birth defects and/or reproductive harm. For more information go to www.P65Warnings.ca.gov.



Motor Specifications

- 120V, 1-Phase, totally enclosed, permanently lubricated
 - 1/12 HP motor is 3-Speed sleeve bearing permanent split capacitor
 - 1/8 HP motor is 3-Speed sleeve bearing permanent split capacitor
 - 1/4 HP motor is 2-Speed ball bearing permanent split capacitor
- Note: Rough-in hole size is 1/2" inch larger than fan blade size

Standard Models

FAN SIZE	MFG CATALOG NUMBER	MFG MODEL NUMBER	HP	CFM / RPM			AMPS HIGH	WT. (LBS)	LIST
				HIGH	MED	LOW			
10"	08689902	CE 10-DS	1/12	680 / 1560	540 / 1250	460 / 1080	1	11	348
12"	07986202	CE 12-DS	1/12	825 / 1560	710 / 1250	560 / 1080	1.1	16	393
14"	08690002	CE 14-DS	1/8	1520 / 1660	1400 / 1550	1250 / 1370	2	17	498
16"	08690102	CE 16-DS	1/8	2100 / 1660	1900 / 1550	1700 / 1370	2.1	18	521
18"	07986302	CE 18-DS	1/8	2300 / 1660	2100 / 1050	1850 / 1370	2.2	25	566
20"	08690202	CE 20-DS	1/4	2925 / 1140	-	2380 / 1070	2.3	34	671
24"	07986402	CE 24-DS	1/4	3400 / 1140	-	2770 / 1070	2.5	47	746
30"	07986502	CE 30-DS	1/4	3950 / 1140	-	3080 / 1070	2.7	54	934

Dimensions (Inches)

SIZE	DEPTH	DIMENSIONS		
		"A"	"B"	"C"
10"	5.81"	13.125"	10"	12.375"
12"	7.18"	15.125"	12"	14.375"
14"	7.18"	17.125"	14"	16.375"
16"	7.18"	19.125"	16"	18.250"
18"	7.18"	21.125"	18"	21.750"
20"	7.18"	23.125"	20"	23.686"
24"	7.18"	27.125"	24"	27.750"
30"	7.18"	33.125"	30"	33.750"

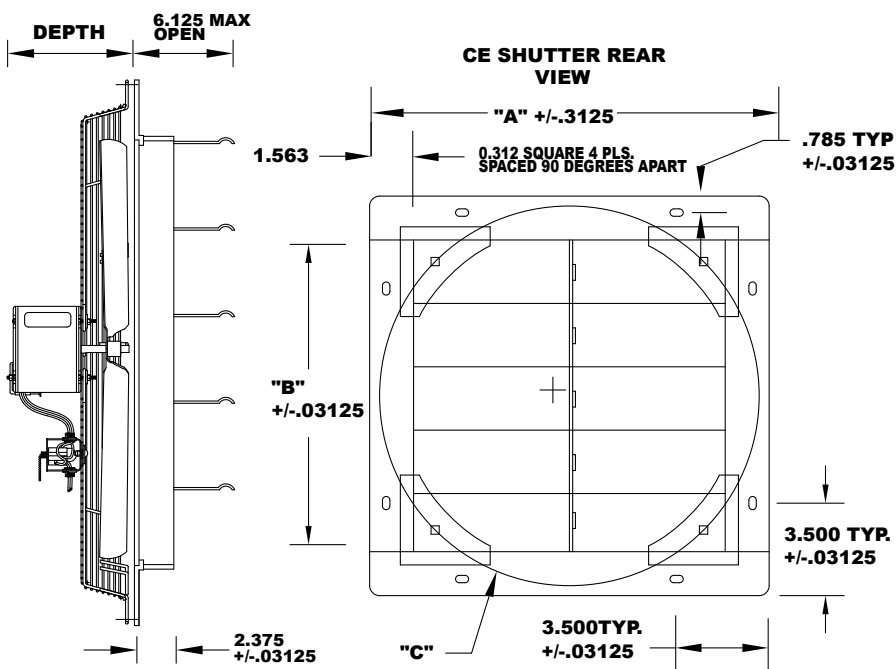

Guard Mounted Direct Drive Exhaust Fans

Features

- Bolts directly to the wall
 - Can be used with or without external shutter
 - Pull chain switch
 - No Cord-Junction box provided for direct wiring
 - Aluminum blade
 - Steel spiral wire guards
 - Made in U.S.A. with domestic and foreign components.
- Note: Rough-in hole size is 1/2" inch larger than fan blade size

⚠ WARNING: This product can expose you to chemicals including nickel which is known to the State of California to cause cancer, and chromium, which is known to the State of California to cause birth defects and/or reproductive harm. For more information go to www.P65Warnings.ca.gov.

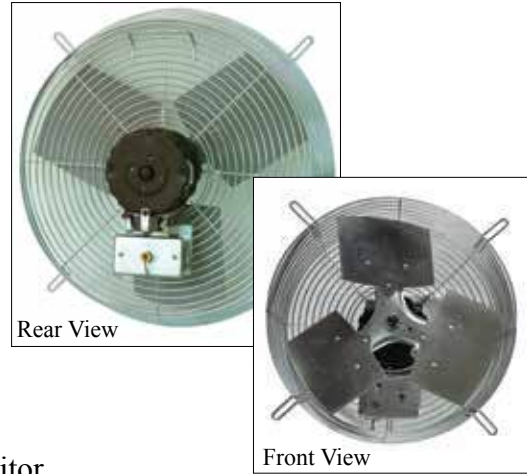

Motor Specifications

- 120V, 1-Phase, totally enclosed, permanently lubricated
- 1/12 HP motor is 3-Speed sleeve bearing permanent split capacitor
- 1/8 HP motor is 3-Speed sleeve bearing permanent split capacitor
- 1/4 HP motor is 2-Speed ball bearing permanent split capacitor

Standard Models

FAN SIZE	MFG CATALOG NUMBER	MFG MODEL NUMBER	HP	CFM / RPM			AMPS HIGH	WT. (LBS)	LIST
				HIGH	MED	LOW			
10"	08689502	CE 10-D	1/12	680 / 1560	540 / 1250	460 / 1080	1	11	295
12"	07985002	CE 12-D	1/12	825 / 1560	710 / 1250	560 / 1080	1.1	12	333
14"	08689602	CE 14-D	1/8	1520 / 1660	1400 / 1550	1250 / 1370	2	17	353
16"	08689702	CE 16-D	1/8	2100 / 1660	1900 / 1550	1700 / 1370	2.1	18	370
18"	07984902	CE 18-D	1/8	2300 / 1660	2100 / 1050	1850 / 1370	2.2	19	407
20"	08689802	CE 20-D	1/4	2925 / 1140	-	2380 / 1070	2.3	34	528
24"	07984802	CE 24-D	1/4	3400 / 1140	-	2770 / 1070	2.5	38	588
30"	07984702	CE 30-D	1/4	3950 / 1140	-	3080 / 1070	2.7	42	685

Dimensions (Inches)

SIZE	BOLT HOLE CENTER WIDTH	DEPTH
10"	14.14"	5.81"
12"	16.46"	7.18"
14"	18.30"	7.18"
16"	20.34"	7.18"
18"	22.64"	7.18"
20"	25.46"	7.18"
24"	29.08"	7.18"
30"	34.89"	7.18"

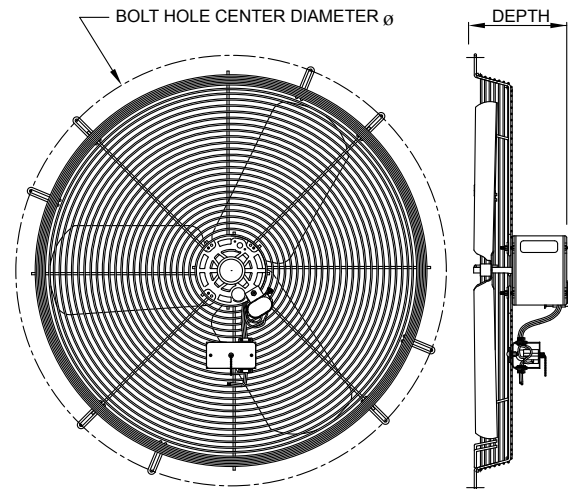

Optional Wall Shutters

FAN SIZE	MFG CATALOG NUMBER	MFG MODEL NUMBER	WT. (LBS)	LIST
10"	08684302	CES-10G	5	79
12"	07985502	CES-12G	5.5	109
14"	08684502	CES-14G	6.5	133
16"	08514702	CES-16G	8	154
18"	07985602	CES-18G	9	187
20"	07975202	CES-20G	10	208
24"	07985702	CES-24G	13	231
30"	07985802	CES-30G	19	270

Venturi Mounted Direct Drive Exhaust Fans

Features

- Can be installed from inside wall
- Can be used with external shutter
- Pull chain switch
- No Cord-Junction box provided for direct wiring
- Aluminum blade
- Steel spiral wire guards
- Made in U.S.A. with domestic and foreign components.

⚠ WARNING: This product can expose you to chemicals including nickel which is known to the State of California to cause cancer, and chromium, which is known to the State of California to cause birth defects and/or reproductive harm. For more information go to www.P65Warnings.ca.gov.



Motor Specifications

- 120V, 1-Phase, totally enclosed, permanently lubricated
 - 1/12 HP motor is 3-Speed sleeve bearing permanent split capacitor
 - 1/8 HP motor is 3-Speed sleeve bearing permanent split capacitor
 - 1/4 HP motor is 2-Speed ball bearing permanent split capacitor
- Note: Rough-in hole size is 1/2" inch larger than fan blade size

Standard Models

FAN SIZE	MFG CATALOG NUMBER	MFG MODEL NUMBER	HP	CFM / RPM			AMPS HIGH	WT. (LBS)	LIST
				HIGH	MED	LOW			
10"	08690302	CE 10-DV	1/12	680 / 1560	540 / 1250	460 / 1080	1	11	348
12"	07986602	CE 12-DV	1/12	825 / 1560	710 / 1250	560 / 1080	1.1	17	392
14"	08690402	CE 14-DV	1/8	1520 / 1660	1400 / 1550	1250 / 1370	2	17	498
16"	08690502	CE 16-DV	1/8	2100 / 1660	1900 / 1550	1700 / 1370	2.1	18	521
18"	07986702	CE 18-DV	1/8	2300 / 1660	2100 / 1050	1850 / 1370	2.2	26	566
20"	08690602	CE 20-DV	1/4	2925 / 1140	-	2380 / 1070	2.3	34	671
24"	07986802	CE 24-DV	1/4	3400 / 1140	-	2770 / 1070	2.5	48	746
30"	07986902	CE 30-DV	1/4	3950 / 1140	-	3080 / 1070	2.7	55	934

Dimensions (Inches)

SIZE	DEPTH	DIMENSIONS				
		"A"	"B"	"C"	"D"	"E"
10"	5.81"	10.250"	12.63"	12.375"	2.000"	12.875"
12"	7.18"	12.250"	14.50"	14.375"	2.000"	14.625"
14"	7.18"	14.250"	17.13"	16.375"	2.500"	17.375"
16"	7.18"	16.250"	19.13"	18.250"	2.875"	20.000"
18"	7.18"	18.125"	21.00"	21.750"	2.750"	22.875"
20"	7.18"	20.250"	23.13"	23.686"	2.750"	25.625"
24"	7.18"	24.250"	29.50"	27.750"	2.875"	27.875"
30"	7.18"	30.250"	33.50"	33.750"	2.875"	33.875"

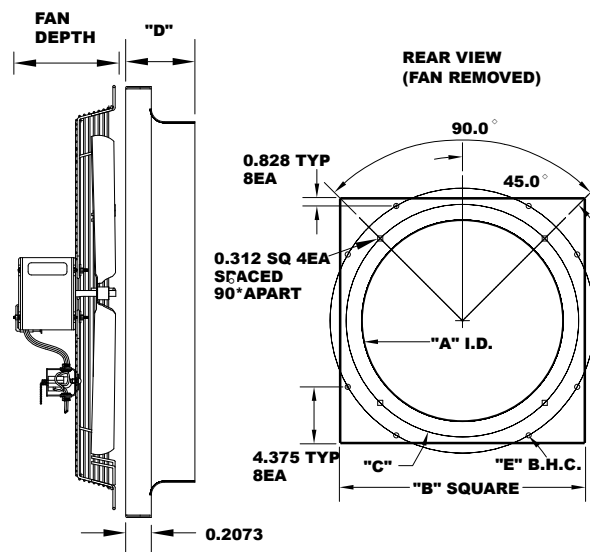

Optional Wall Shutters

FAN SIZE	MFG CATALOG NUMBER	MFG MODEL NUMBER	DIMENSIONS		WT. (LBS)	LIST
			WIDTH	LENGTH		
10"	08684302	CES-10G	13.13"	13.13"	5.0	79
12"	07985502	CES-12G	15.13"	15.13"	5.5	109
14"	08684502	CES-14G	17.13"	17.13"	6.5	133
16"	08514702	CES-16G	19.00"	19.00"	8.0	154
18"	07985602	CES-18G	21.13"	21.13"	9.0	187
20"	07975202	CES-20G	23.13"	23.13"	10.0	208
24"	07985702	CES-24G	27.13"	27.13"	13.0	231
30"	07985802	CES-30G	33.13"	33.13"	19.0	270

Commercial Exhaust Fans & Shutters

Belt-Drive Exhaust Fan

Features

- 120V, 1 phase or 230 / 460V, 3-Phase, ball bearing, permanently lubricated, drip proof motor
- Permanently lubricated bearings on blade drive shaft
- Aluminum blade
- Powder coated venturi
- 1725 RPM
- Motor frame size 56
- 5/8" shaft
- 1 year warranty
- Made in U.S.A.

⚠ WARNING: This product can expose you to chemicals including nickel which is known to the State of California to cause cancer, and chromium, which is known to the State of California to cause birth defects and/or reproductive harm. For more information go to www.P65Warnings.ca.gov.



Dimensions (Inches)

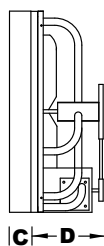
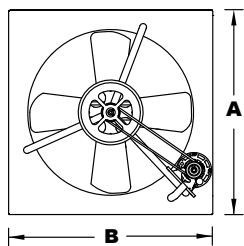

MODEL	DIMENSIONS A x B x C x D
CE-24B	29.5" x 28" x .75" x 17"
CE-30B	35.5" x 34" x .75" x 17"
CE-36B	41.5" x 40" x .75" x 17"
CE-42B	48" x 48" x .75" x 17"
CE-48B	54" x 54" x .75" x 17"

Standard Models

SIZE	MOTOR HP	AMPS		CFM	WT. (LBS)	115V 1-PHASE			230/460V 3-PHASE		
		115V	230/460V			MFG CATALOG NUMBER	MFG MODEL NUMBER	LIST	MFG CATALOG NUMBER	MFG MODEL NUMBER	LIST
24	1/3	5	1.9 / .9	3000	50	07967002	CE-24B	845	08510402	CE-24B-3	971
30	1/3	6	1.9 / .9	4500	60	07967102	CE-30B	951	08510502	CE-30B-3	1085
36	1/2	8	2.3 / 1.1	6900	65	07967202	CE-36B	1098	08510602	CE-36B-3	1228
42	3/4	11	3.3 / 1.5	10600	75	07967302	CE-42B	1379	08510702	CE-42-B-3	1710
48	1	15	3.8 / 1.9	14400	98	07967402	CE-48B	1723	08510802	CE-48-B-3	1822

Optional Exhaust Shutters



Features

- Air open - gravity close
- Aluminum frame
- Aluminum blade
- Weather stripping for tighter seal
- For CE Series Belt Drive Fans
- Made in U.S.A.

Standard Models

MFG CATALOG NUMBER	MFG MODEL NUMBER	WT. (LBS)	LIST
07967502	CES-24	11	284
07967602	CES-30	15	348
07967702	CES-36	19	608
07967802	CES-42	23	773
07967902	CES-48	28	891

Shutter Dimensions (Inches)

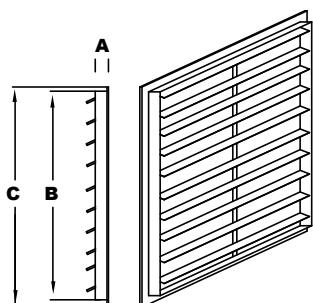

- (A) Thickness
- (B) Blade Housing Size
- (C) Overall Size

MFG MODEL NUMBER	OUTSIDE FRAME DIMENSIONS A x C x C	INSIDE FRAME DIMENSIONS B x B
CES-24	3" x 27" x 27"	24" x 24"
CES-30	3" x 33" x 33"	30" x 30"
CES-36	3" x 39" x 39"	36" x 36"
CES-42	3" x 45" x 45"	42" x 42"
CES-48	3" x 51" x 51"	48" x 48"

* Recommend adding 1/2" to inside frame dimension for wall opening.

Industrial Direct Drive Exhaust Fans

Features

- Totally enclosed motors:
 - 1-Phase motors are field convertible 115V / 230V
 - 3-Phase motors are field convertible 230V / 460V
 - Motors are set to lower voltage at the factory, unless a request is made at time of order to set to the higher voltage
- 14 gauge steel venturi with steel pipe bracing
- 4-blade steel propeller
- 1 year limited warranty

⚠ WARNING: This product can expose you to chemicals including nickel which is known to the State of California to cause cancer, and chromium, which is known to the State of California to cause birth defects and/or reproductive harm. For more information go to www.P65Warnings.ca.gov.



Options

- CES Shutters
- EMF Front Guards
- IBG Rear Guards

Standard Models

BLADE SIZE	MFG MODEL NUMBER		PANEL SIZE (Sq.)	HP	RPM	CFM 0" SP	db's @ 10'	WT. (LBS)	LIST	
	1-PHASE	3-PHASE							TEC	
	115/230V-60Hz	208/230/460v-60Hz							1 PH	3 PH
12"	IED12-1/4	IED12-1/4-3	16"	1/4	1725	1480	64	30	1443	1448
16"	IED16-1/3	IED16-1/3-3	20"	1/3	1725	2834	73	40	1728	1763
18"	IED18-1/2	IED18-1/2-3	24"	1/2	1725	3890	74	55	1941	1957
20"	IED20-3/4	IED20-3/4-3	24"	3/4	1725	4574	77	65	2255	2255
24"	IED24-1	IED24-1-3	30"	1	1725	6632	81	155	2602	2461
30"	IED30-1	IED30-1-3	36"	1	1150	8600	79	185	5094	2949
36"	IED36-1 1/2	IED36-1 1/2-3	42"	1.5	1150	12103	82	260	6421	3945
42"	-----	IED42-2-3	48"	2	1150	17315	87	280	--	4229
48"	-----	IED48-3-3	54"	3	850	24280	86	360	--	5928

Note: Products listed in this section are custom built and subject to 100% cancellation/restocking charges.

Dimensions

SIZE	BLADE DIAMETER	PANEL SIZE	DEPTH DIMENSION
12"	12"	16"	11"
16"	16"	20"	11"
20"	20"	24"	13"
24"	24"	30"	15"
30"	30"	36"	15"
36"	36"	42"	18"
42"	42"	48"	18"
48"	48"	54"	20"

Note: Depth dimension varies with motor selection.

Industrial Belt Drive Exhaust Fans

Features

- Totally enclosed motors:
 - 1-Phase motors are field convertible 115V / 230V
 - 3-Phase motors are field convertible 230V / 460V
 - Motors are set to lower voltage at the factory, unless a request is made at time of order to set to the higher voltage
- 16 gauge steel venturi with steel pipe bracing
- Steel blades
- Double pillow block bearing shaft support
- 1 year limited warranty



⚠ WARNING: This product can expose you to chemicals including nickel which is known to the State of California to cause cancer, and chromium, which is known to the State of California to cause birth defects and/or reproductive harm. For more information go to www.P65Warnings.ca.gov.

Options

- CES Shutters
- EMF Front Guard
- IBG Rear Guards

Standard Models

BLADE SIZE	MFG MODEL NUMBER		PANEL SIZE (Sq.)	HP	RPM	CFM	db's @ 10'	WT. (LBS)	LIST	
	1-PHASE	3-PHASE							1 PH	3PH
	115/230V-60Hz	208/230/460v-60Hz								
24"	IE24-1/3	IE24-1/3-3	30"	1/3	825	5300	61	70	2507	2527
	IE24-1/2	IE24-1/2-3		1/2	925	6200	66	75	2589	2603
	IE24-3/4	IE24-3/4-3		3/4	1050	7000	71	82	2804	2632
	IE24-1	IE24-1-3		1	1175	7800	73	90	2833	2698
30"	IE30-1/3	IE30-1/3-3	36"	1/3	570	7500	62	95	2622	2642
	IE30-1/2	IE30-1/2-3		1/2	625	8500	64	95	2924	2726
	IE30-3/4	IE30-3/4-3		3/4	725	10000	66	105	2929	2764
	IE30-1	IE30-1-3		1	825	11000	70	115	2994	2858
36"	IE36-1/3	IE36-1/3-3	42"	1/3	425	9000	64	103	2886	2902
	IE36-1/2	IE36-1/2-3		1/2	500	10500	66	105	2973	2994
	IE36-3/4	IE36-3/4-3		3/4	575	11900	68	110	3235	3025
	IE36-1	IE36-1-3		1	650	13100	70	120	3219	3084
	IE36-1 1/2	IE36-1 1/2-3		1 1/2	750	15000	72	155	3679	3512
	IE36-2	IE36-2-3		2	830	16500	74	165	----	3584
42"	IE42-3/4	IE42-3/4-3	48"	3/4	430	14000	67	175	3608	3443
	IE42-1	IE42-1-3		1	490	15400	69	180	3634	3507
	IE42-1 1/2	IE42-1 1/2-3		1 1/2	550	17200	71	185	3807	3646
	IE42-2	IE42-2-3		2	620	19400	74	200	----	4158
	-----	IE42-3-3		3	700	22000	79	225	----	4301
48"	IE48-3/4	IE48-3/4-3	54"	3/4	350	17000	70	185	3948	3781
	IE48-1	IE48-1-3		1	400	19100	71	190	3976	3845
	IE48-1 1/2	IE48-1 1/2-3		1 1/2	460	22000	72	200	4141	3980
	IE48-2	IE48-2-3		2	520	24000	74	250	----	4633
	-----	IE48-3-3		3	590	27500	80	260	----	4776
	-----	IE48-5-3		5	660	30500	83	280	----	4813
60"	IE60-2	IE60-2-3	66"	2	320	31000	77	320	----	6447
	-----	IE60-3-3		3	370	35000	84	330	----	6588
	-----	IE60-5-3		5	420	39000	86	350	----	6644

Note: Products listed in this section are custom built and subject to 100% cancellation/restocking charges.

Dimensions

SIZE	BLADE DIAMETER	PANEL SIZE	DEPTH DIMENSION
24"	24"	30"	18"
30"	30"	36"	18"
36"	36"	42"	20"
42"	42"	48"	20"
48"	48"	54"	22"
60"	60"	66"	28"

Note: Depth dimension varies with motor selection.

Heavy Duty Direct Drive Exhaust Fans

Features

- Totally enclosed and explosion proof motors.
 - Explosion proof motors are Class 1, Div 1 Group D and Class 2, Div 1, Groups F & G
- Fans are shipped completely assembled
- Cast aluminum blades
- 14 gauge steel panel with welded steel pipe bracing
- 1 year limited warranty

⚠ WARNING: This product can expose you to chemicals including nickel which is known to the State of California to cause cancer, and chromium, which is known to the State of California to cause birth defects and/or reproductive harm. For more information go to www.P65Warnings.ca.gov.



Options

- CES Shutters
- EMF Front Guards
- IBG Rear Guards
- Acid Resistant Coating
- Reversed Air Flow
- Flat Front Venturi

Standard Models

BLADE SIZE	MFG MODEL NUMBER		PANEL SIZE (Sq.)	HP	RPM	CFM 0° SP	db's @ 10'	WT. (LBS)	LIST			
	1-PHASE	3-PHASE							TEC		EXP*	
	115/230V-60Hz	208/230/460v-60Hz							1 PH	3 PH	1 PH	3 PH
12"	EHD12-1/4	EHD12-1/4-3	16"	1/4	1725	1180	74	35	1827	1817	2289	2366
16"	EHD16-1/4	EHD16-1/4-3	20"	1/4	1725	2800	75	45	2229	2242	2691	2769
18"	EHD18-1/3	EHD18-1/3-3	24"	1/3	1725	3375	75	60	2366	2385	2969	3130
	EHD18-1/2	EHD18-1/2-3		1/2	1725	4150	76	60	2468	2484	3176	3143
20"	EHD20-1/4	EHD20-1/4-3	30"	1/4	1725	3720	75	60	2262	2250	2729	2801
	EHD20-1/2	EHD20-1/2-3		1/2	1725	4800	76	65	2437	2457	3149	3117
	EHD20-1	EHD20-1-3		1	1725	6900	77	70	2723	2592	3402	3460
24"	EHD24-1/4	EHD24-1/4-3	36"	1/4	1725	5200	82	135	2399	2385	2863	2942
	EHD24-1/3	EHD24-1/3-3		1/3	1150	4975	75	145	2902	2942	3887	3941
	EHD24-1/2	EHD24-1/2-3		1/2	1725	6510	82	140	2657	2669	3364	3332
	EHD24-3/4	EHD24-3/4-3		3/4	1725	6900	83	145	2870	2708	3585	3410
	EHD24-1	EHD24-1-3		1	1725	7425	83	155	2949	2812	3630	3686
	EHD24-2	EHD24-2-3		2	1725	9525	83	165	3720	3052	---	4071
	-----	EHD24-3-3	3	1725	10500	85	170	---	3317	---	4405	
30"	EHD30-1/3	EHD30-1/3-3	42"	1/3	1150	6950	79	145	3176	3215	4159	4220
	EHD30-1/2	EHD30-1/2-3		1/2	1725	8980	89	135	2956	2969	3662	3630
	EHD30-3/4	EHD30-3/4-3		3/4	1150	10440	79	175	3784	3377	4362	4232
	-----	EHD30-1-3		1	870	10640	74	215	---	4173	---	---
	EHD30-1 1/2	EHD30-1 1/2-3		1 1/2	1725	12000	89	165	3442	3273	5315	4283
	EHD30-2	EHD30-2-3		2	1150	14000	82	215	---	3902	---	5059
	-----	EHD30-3-3	3	1725	16000	89	190	---	3507	---	4588	
36"	EHD36-1	EHD36-1-3	48"	1	1150	13600	84	225	5449	4353	6544	5165
	EHD36-2	EHD36-2-3		2	1150	17620	84	250	---	4483	---	5644
	-----	EHD36-3-3		3	1150	20500	85	255	---	5152	---	6518
	-----	EHD36-5-3		5	1725	28000	94	250	---	4322	---	5508
42"	-----	EHD42-1-3	54"	1	870	15800	82	300	---	5059	---	---
	EHD42-2	EHD42-2-3		2	1150	17964	88	260	---	4768	---	5929
	-----	EHD42-3-3		3	1150	24500	88	270	---	5359	---	6724
	-----	EHD42-5-3		5	1150	28970	88	285	---	5571	---	7521
48"	-----	EHD48-3-3	66"	3	1150	28600	92	290	---	6466	---	7833
	-----	EHD48-5-3		5	1150	32000	94	305	---	6772	---	8727
60"	-----	EHD60-3-3	72"	3	1150	40000	97	700	---	8029	---	9392
	-----	EHD60-5-3		5	1150	45000	97	730	---	8786	---	10743
	-----	EHD60-7 1/2-3		7 1/2	870	47000	92	740	---	11538	---	---
	-----	EHD60-10-3		10	870	57200	93	750	---	15462	---	---

Single Phase motors are field convertible 115V/230V. Three phase motors are field convertible 230V/460V. Motors are set to lower voltage at the factory, unless a request is made at time of order to set to the higher voltage. Note: Products listed in this section are custom built and subject to 100% cancellation/restocking charges. *Not all EXP motors are 208V capable.

Dimensions

SIZE	BLADE DIAMETER	PANEL SIZE	DEPTH DIMENSION
12"	12"	16"	11"
16"	16"	20"	11"
20"	20"	24"	13"
24"	24"	30"	15"
30"	30"	36"	15"
36"	36"	42"	18"
42"	42"	48"	18"
48"	48"	54"	20"
60"	60"	66"	22"

Note: Depth dimension varies with motor selection.

Heavy Duty Belt Drive Exhaust Fans

Features

- Totally enclosed and explosion proof motors
 - Explosion proof motors are Class 1, Div 1 Group D and Class 2, Div 1, Groups F & G
- Fans are shipped completely assembled
- Heavy gauge steel blades on TEC models
- Cast aluminum blades on EXP explosion proof models
- 14 gauge steel panel with welded steel pipe bracing
- 1 year limited warranty
- For optimum shutter efficiency, mount shutter 1/2 the distance of the fan opening size.
Example: 36" fan shutter would be mounted 12" from the fan blade.

⚠ WARNING: This product can expose you to chemicals including nickel which is known to the State of California to cause cancer, and chromium, which is known to the State of California to cause birth defects and/or reproductive harm. For more information go to www.P65Warnings.ca.gov.



Options

- CES Shutters
- Reversed Air Flow
- EMF Front Guards
- Flat Front Venturi
- IBG Rear Guards

Standard Models

BLADE SIZE	MFG MODEL NUMBER		PANEL SIZE (Sq.)	HP	RPM	CFM 0" SP	db's @ 10"	WT. (LBS)	LIST			
	1-PHASE	3-PHASE							TEC		EXP*	
	115/230V-60Hz	208/230/460v-60Hz							1 PH	3 PH	1 PH	3 PH
24"	EHB24-1/4	EHB24-1/4-3	30"	1/4	780	4900	60	100	3021	3008	4104	4182
	EHB24-1/2	EHB24-1/2-3		1/2	980	6219	66	130	3196	3209	4518	4479
	EHB24-3/4	EHB24-3/4-3		3/4	1140	7090	71	140	3416	3240	4745	4569
	EHB24-1	EHB24-1-3		1	1250	7180	73	140	3638	3499	4795	4860
30"	EHB30-1/4	EHB30-1/4-3	36"	1/4	540	7178	61	140	3222	3209	4512	4590
	EHB30-1/3	EHB30-1/3-3		1/3	595	7909	63	150	3279	3300	4707	4867
	EHB30-1/2	EHB30-1/2-3		1/2	640	8507	64	155	3364	3377	4921	4887
	EHB30-3/4	EHB30-3/4-3		3/4	770	10235	66	165	3656	3481	5218	5042
	EHB30-1	EHB30-1-3		1	975	10668	70	170	3843	3709	5262	5329
	EHB30-1 1/2	EHB30-1 1/2-3		1 1/2	1140	12473	77	180	4010	3831	6641	5600
36"	EHB36-1/3	EHB36-1/3-3	42"	1/3	460	9113	64	160	3811	3831	5121	5282
	EHB36-1/2	EHB36-1/2-3		1/2	530	10500	66	180	3903	3915	5450	5412
	EHB36-3/4	EHB36-3/4-3		3/4	605	11985	68	200	4154	3987	5703	5529
	EHB36-1	EHB36-1-3		1	665	13174	70	200	4182	4043	5710	5767
	EHB36-1 1/2	EHB36-1 1/2-3		1 1/2	720	13660	72	210	4712	4544	7237	6190
	EHB36-2	EHB36-2-3		2	870	16554	74	215	5205	4659	----	6416
42"	EHB42-1/3	EHB42-1/3-3	48"	1/3	335	10614	64	205	3966	3987	5600	5761
	EHB42-1/2	EHB42-1/2-3		1/2	390	12343	65	210	4050	4065	5793	5767
	EHB42-3/4	EHB42-3/4-3		3/4	435	14040	67	225	4317	4148	6131	5948
	EHB42-1	EHB42-1-3		1	490	15429	69	230	4374	4237	6136	6190
	EHB42-1 1/2	EHB42-1 1/2-3		1 1/2	550	17420	71	240	4550	4382	7535	6487
	EHB42-2	EHB42-2-3		2	725	20653	74	245	5393	4847	----	6774
	----	EHB42-3-3		3	830	23645	79	250	----	5005	----	6986
48"	EHB48-1/2	EHB48-1/2-3	54"	1/2	330	15230	69	190	5010	5022	6966	6934
	EHB48-3/4	EHB48-3/4-3		3/4	370	17339	70	195	5255	5088	7387	7211
	EHB48-1	EHB48-1-3		1	410	19188	71	235	5289	5152	7393	7459
	EHB48-1 1/2	EHB48-1 1/2-3		1 1/2	465	21731	72	245	5502	5334	8781	7730
	EHB48-2	EHB48-2-3		2	520	24274	74	250	6384	5839	----	7981
	----	EHB48-3-3		3	680	28150	80	270	----	6008	----	8218
	----	EHB48-5-3		5	800	33160	83	285	----	6078	----	8378
60"	EHB60-1	EHB60-1-3	66"	1	280	23090	76	380	7374	7237	9991	10057
	EHB60-1 1/2	EHB60-1 1/2-3		1 1/2	340	28068	77	390	7549	7382	11385	10341
	EHB60-2	EHB60-2-3		2	390	32200	78	395	7998	7452	----	10478
	----	EHB60-3-3		3	450	37183	84	410	----	7815	----	10821
	----	EHB60-5-3		5	540	44600	86	420	----	7874	----	10976

Single Phase motors are field convertible 115V/230V. Three phase motors are field convertible 230V/460V. Motors are set to lower voltage at the factory, unless a request is made at time of order to set to the higher voltage. Note: Products listed in this section are custom built and subject to 100% cancellation/restocking charges. *Not all EXP motors are 208V capable.

Dimensions

SIZE	BLADE DIAMETER	PANEL SIZE	DEPTH DIMENSION
24"	24"	30"	16"
30"	30"	36"	16"
36"	36"	42"	18"
42"	42"	48"	20"
48"	48"	54"	21"
60"	60"	66"	26"

Note: Depth dimension varies with motor selection.

Cabinet Exhaust Fans With Shutters

Features

- 120V, 1-Phase or 230 / 460V, 3-Phase, ball bearing, permanently lubricated, drip proof motor - UL listed
- Permanently lubricated bearings on blade drive shaft
- Aluminum blade
- Aluminum shutter
- 20 gauge powder coated venturi
- 18 gauge galvanized steel housing
- 1725 RPM motor
- Motor frame size 56 / Shaft: 5/8"
- Ships fully assembled
- Meets OSHA Standards
- 1 year warranty
- Made in U.S.A.



WARNING: This product can expose you to chemicals including nickel which is known to the State of California to cause cancer, and chromium, which is known to the State of California to cause birth defects and/or reproductive harm. For more information go to www.P65Warnings.ca.gov.

Standard Models

SIZE	MOTOR	AMPS		CFM	WT. (LBS)	115V 1-PHASE			230 / 460V 3-PHASE			
		HP	115V			230/460V	MFG CATALOG NUMBER	MFG MODEL NUMBER	LIST	MFG CATALOG NUMBER	MFG MODEL NUMBER	LIST
30	1/3	6	1.9 / .9	4500	120	08684002	CBT-30B	2012	08685302	CBT-30B-3	2159	
36	1/2	8	2.3 / 1.1	6900	135	08684102	CBT-36B	2271	08685402	CBT-36B-3	2458	
42	3/4	11	3.3 / 1.5	10600	155	08684202	CBT-42B	2793	08685502	CBT-42B-3	3014	
48	1	15	3.8 / 1.9	14400	200	08685102	CBT-48B	3461	08685002	CBT-48B-3	3686	

Dimensions

SIZE	OUTSIDE DIMENSIONS			MAXIMUM REQUIRED INSIDE WALL OPENING
	HEIGHT	WIDTH	DEPTH	
24"	28 1/4"	28 1/4"	22 1/2"	28 3/4" x 28 3/4"
30"	34 1/4"	34 1/4"	22 1/2"	34 1/2" x 34 1/2"
36"	40 1/4"	40 1/4"	18 1/2"	40 1/2" x 40 1/2"
42"	48 1/2"	48 1/2"	18 1/2"	48 3/4" x 48 3/4"
48"	54 1/2"	54 1/2"	21 1/2"	54 3/4" x 54 3/4"

Exhaust Fan Accessories - Heavy Duty Exhaust Shutter

Features

- Air open - Gravity close
- Aluminum construction
- Heavy duty blades
- Weather stripping for tighter seal
- For optimum shutter efficiency, mount shutter 1/3 the distance of the fan opening size. Example: 36" fan shutter would be mounted 12" from the fan blade.
- Shutter should be sized to fit exhaust opening
- For IE, IED, EHB and EHD models

Standard Models

FAN SIZE	MFG MODEL NUMBER	INSIDE FRAME DIMENSIONS	OUTSIDE FRAME DIMENSIONS	WT. (LBS)	LIST
12"	CES 12-HD	12" x 12"	14" x 15"	4	165
16"	CES 16-HD	16" x 16"	19" x 19"	7	199
18"	CES 18-HD	18" x 18"	21" x 21"	8	228
20"	CES 20-HD	20" x 20"	23" x 23"	9	233
24"	CES 24-HD	24" x 24"	27" x 27"	11	284
30"	CES 30-HD	30" x 30"	33" x 33"	15	348
36"	CES 36-HD	36" x 36"	39" x 39"	19	608
42"	CES 42-HD	42" x 42"	45" x 45"	23	773
48"	CES 48-HD	48" x 48"	51" x 51"	28	891
54"	CES 54-HD	54" x 54"	57" x 57"	39	1007
60"	CES 60-HD	60" x 60"	63" x 63"	47	1237



WARNING: This product can expose you to chemicals including nickel which is known to the State of California to cause cancer, and chromium, which is known to the State of California to cause birth defects and/or reproductive harm. For more information go to www.P65Warnings.ca.gov.



Heavy Duty Shutter Motor Kit Features

- Used to open shutter when shutter is used to provide make-up air (Shutter should be one size larger than exhaust fan size and should be located on opposite wall)
- Used for positive closure of exhaust shutter
- 115V or 230V, 60 HZ, 1-Phase

Standard Models

MFG CATALOG NUMBER	MFG MODEL NUMBER	DESCRIPTION	WT. (LBS)	LIST
07971002	MK-1	For shutter sizes 12" thru 30" (Single Panel)	5	460
07971102	MK-2	For shutter sizes 36" thru 48" (Double Panel)	8	608
08777102	MK-3	For shutter sizes 54" thru 72" (Double Panel)	12	783

Motorized Supply Air Intake Shutter

Features

- Inward opening blades for use with intake fans when shutter is located directly in air stream
- Galvanized construction
- 115V or 230V, 60 HZ, 1-Phase
- For IE, IED, EHB and EHD models

Standard Models

FAN SIZE	MFG MODEL NUMBER	ROUGH OPENING	OVERALL SIZE	WT. (LBS)	LIST
24"	CESM-24	24" x 24"	27" x 27"	15	1175
30"	CESM-30	30" x 30"	33" x 33"	18	1372
36"	CESM-36	36" x 36"	39" x 39"	21	1499
42"	CESM-42	42" x 42"	45" x 45"	35	2448
48"	CESM-48	48" x 48"	51" x 51"	42	3458
60"	CESM-60	60" x 60"	63" x 63"	56	4078



WARNING: This product can expose you to chemicals including nickel which is known to the State of California to cause cancer, and chromium, which is known to the State of California to cause birth defects and/or reproductive harm. For more information go to www.P65Warnings.ca.gov.

Rear Box Guard Bolt Together With Wire Guards



⚠ WARNING: This product can expose you to chemicals including nickel which is known to the State of California to cause cancer, and chromium, which is known to the State of California to cause birth defects and/or reproductive harm. For more information go to www.P65Warnings.ca.gov.

Features

- For IE, IED, EHB and EHD models
- 1/4" Smaller than the panel size of the fan
- Meets OSHA requirements

Standard Models

MFG MODEL NUMBER	FITS FAN SIZE	LIST
IBG-24	24"	1029
IBG-30	30"	1084
IBG-36	36"	1304
IBG-42	42"	1368
IBG-48	48"	1676
IBG-60	60"	2586

Rear Expanded Metal Box Guard



⚠ WARNING: This product can expose you to chemicals including nickel which is known to the State of California to cause cancer, and chromium, which is known to the State of California to cause birth defects and/or reproductive harm. For more information go to www.P65Warnings.ca.gov.

Features

- For IE, IED, EHB and EHD models
- 1/4" Smaller than the panel size of the fan
- Meets OSHA requirements

Standard Models

MFG MODEL NUMBER	FITS FAN SIZE	LIST
IBG-12	12"	631
IBG-16	16"	631
IBG-18	18"	699
IBG-20	20"	699

Spiral Front and Rear Guards

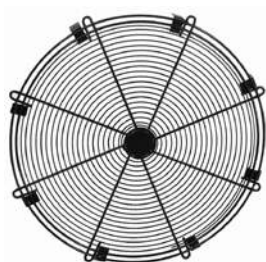

Spiral Front

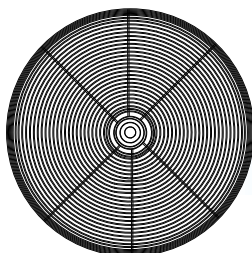

Spiral Rear

⚠ WARNING: This product can expose you to chemicals including nickel which is known to the State of California to cause cancer, and chromium, which is known to the State of California to cause birth defects and/or reproductive harm. For more information go to www.P65Warnings.ca.gov.

Features

- For EHD models only
- Fits between motor and blade
- Rear guard installed at factory only
- Meets OSHA requirements

Standard Models

MFG MODEL NUMBER	TYPE	FITS FAN SIZE	LIST
SF-12	SPIRAL FRONT	12"	347
SF-16		16"	371
SF-18		18"	411
SF-20		20"	422
SF-24		24"	454
SR-12	SPIRAL REAR	12"	359
SR-16		16"	382
SR-18		18"	422
SR-20		20"	436
SR-24		24"	469

Expanded Metal Front Guard

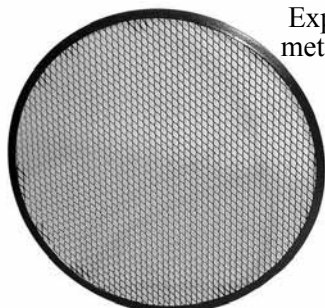

Expanded metal guard
60"

⚠ WARNING: This product can expose you to chemicals including nickel which is known to the State of California to cause cancer, and chromium, which is known to the State of California to cause birth defects and/or reproductive harm. For more information go to www.P65Warnings.ca.gov.

Features

- For EHB, EHD, IE, & IED models
- 1" Larger than blade size
- Meets OSHA requirements

Standard Models

MFG MODEL NUMBER	FITS FAN SIZE	LIST
EMF-12	12"	414
EMF-16	16"	429
EMF-20	20"	453
EMF-24	24"	476
EMF-30	30"	602
EMF-36	36"	745
EMF-42	42"	784
EMF-48	48"	855
EMF-60	60"	1290

Cabinet Exhaust Fan Package Option

With Bolt Together Rear Guard

Package Includes

- Wall collar
- Automatic shutter
- Rear box guard

Features

- For IE, IED, EHB and EHD models.
- Wall collar OD is 1/4" larger than fan panel size.
- Meets OSHA requirements

Standard Models

MFG MODEL NUMBER	FAN SIZE	LIST
CEFP-24	24"	1837
CEFP-30	30"	2074
CEFP-36	36"	2576
CEFP-42	42"	2961
CEFP-48	48"	3533

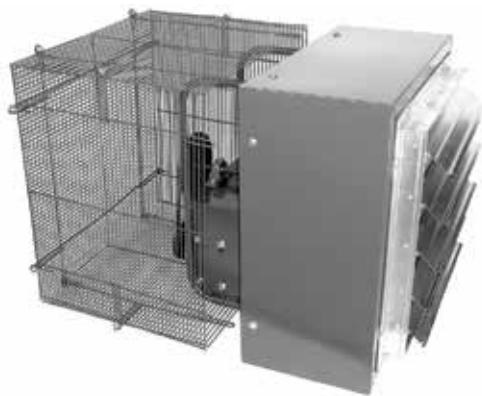

⚠ WARNING: This product can expose you to chemicals including nickel which is known to the State of California to cause cancer, and chromium, which is known to the State of California to cause birth defects and/or reproductive harm. For more information go to www.P65Warnings.ca.gov.

With Expanded Metal Rear Guard

Package Includes

- Wall collar
- Automatic shutter
- Rear box guard

Features

- For IE, IED, EHB and EHD models.
- Wall collar OD is 1/4" larger than fan panel size.
- Meets OSHA requirements

Standard Models

MFG MODEL NUMBER	FAN SIZE	LIST
CEFP-12	12"	1150
CEFP-16	16"	1228
CEFP-18	18"	1386
CEFP-20	20"	1438
CEFP-60	60"	5306



⚠ WARNING: This product can expose you to chemicals including nickel which is known to the State of California to cause cancer, and chromium, which is known to the State of California to cause birth defects and/or reproductive harm. For more information go to www.P65Warnings.ca.gov.

Exterior Weather Hood Option

Features

- For IE, IED, EHB and EHD models.
- Galvanized housing with 1/2 - 16 expanded metal bird screen
- Can be used for intake or exhaust
- Meets OSHA requirements

Standard Models

MFG MODEL NUMBER	FAN SIZE	LIST
WH-12	12"	1155
WH-16	16"	1206
WH-18	18"	1230
WH-20	20"	1251
WH-24	24"	1780
WH-30	30"	1853
WH-36	36"	2298
WH-42	42"	2389
WH-48	48"	2764
WH-60	60"	3695



⚠ WARNING: This product can expose you to chemicals including nickel which is known to the State of California to cause cancer, and chromium, which is known to the State of California to cause birth defects and/or reproductive harm. For more information go to www.P65Warnings.ca.gov.

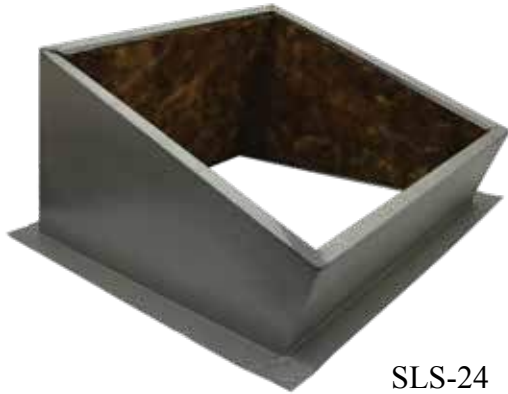

SLS-24

Features

- Used with UEB, UED, and RE roof ventilators
- For flat, single slope or ridge style roofs
- Galvanized steel construction
- 1 1/2" insulated thickness, 3 pounds density
- 8" height overall
- Not for corrugated roofs

⚠ WARNING: This product can expose you to chemicals including nickel which is known to the State of California to cause cancer, and chromium, which is known to the State of California to cause birth defects and/or reproductive harm. For more information go to www.P65Warnings.ca.gov.

Standard Models

FAN	MFG MODEL NUMBER			BASE DIMENSION	OVERALL DIMENSION	LIST		
	FLAT	SLOPE	RIDGE			FLAT	SLOPE	RIDGE
18"	FLS-18	SLS-18	RDS-18	32" x 32"	44" x 44"	550	1061	1251
24"	FLS-24	SLS-24	RDS-24	38" x 38"	50" x 50"	636	1214	1425
30"	FLS-30	SLS-30	RDS-30	44" x 44"	56" x 56"	718	1361	1608
36"	FLS-36	SLS-36	RDS-36	50" x 50"	62" x 62"	784	1492	1718
42"	FLS-42	SLS-42	RDS-42	56" x 56"	68" x 68"	864	1637	1938
48"	FLS-48	SLS-48	RDS-48	62" x 62"	74" x 74"	1163	2200	2608
54"	FLS-54	SLS-54	RDS-54	68" x 68"	80" x 80"	1258	2390	2830
60"	FLS-60	SLS-60	RDS-60	74" x 74"	86" x 86"	1375	2602	3078

Back Draft Dampers to Fit in Curb

UEB and UED models require higher curb height when used with back draft damper; consult factory.

FAN SIZE	MFG MODEL NUMBER	SHUTTER SIZE	LIST
18"	CD-18	28" x 28"	729
24"	CD-24	34" x 34"	850
30"	CD-30	40" x 40"	1172
36"	CD-36	46" x 46"	1449
42"	CD-42	52" x 52"	1600
48"	CD-48	58" x 58"	1941
54"	CD-54	64" x 64"	2434
60"	CD-60	70" x 70"	2646

Motor Kit for Dampers

115V or 230V, 60Hz, 1-Phase. (Specify Voltage)

MFG MODEL NUMBER	DESCRIPTION	WT. (LBS)	LIST
DMKP1	For shutter sizes 18" thru 36"	5	665
DMKP2	For shutter sizes 42" thru 60"	8	792

Belt Drive Hooded Roof Ventilators



CLOSED

WARNING: This product can expose you to chemicals including nickel which is known to the State of California to cause cancer, and chromium, which is known to the State of California to cause birth defects and/or reproductive harm. For more information go to www.P65Warnings.ca.gov.



OPEN

Features

- Used for exhaust or intake
- Heavy industrial steel base with aluminum hood
- Steel blades
- Bird screen included
- No back draft protection in standard construction. Dampers offered as optional accessory.
- 1 year limited warranty

Options

- Direct drive
- Protective coatings, explosion proof.
- Roof curb
- Filters

Dimensions

SIZE	MINIMUM ROOF HOLE (SQUARE)	HOLE LENGTH x WIDTH	HOOD HEIGHT	ROOF CURB O.D. (SQUARE)
24"	30"	54" x 64"	30"	39"
30"	36"	60" x 76"	36"	45"
36"	42"	72" x 82"	40"	51"
42"	48"	80" x 89"	43"	57"
48"	54"	87" x 95"	46"	63"
54"	60"	92" x 98"	54"	69"
60"	66"	90" x 107"	56"	75"

Standard Models

BLADE SIZE	1-PHASE 115/230V	3-PHASE 208/230/460v	HP	RPM	C.F.M. - STATIC PRESSURE				Db's @ 10'	WT. (LBS)	LIST			
					MFG MODEL NUMBER						EXHAUST		INTAKE	
					0"	1/8"	1/4"	1/2"			1 PH	3 PH	1 PH	3 PH
24"	RE24-1/4	RE24-1/4-3	1/4	780	4900	4222	2807	800	60	340	6927	6898	6927	6898
	RE24-1/2	RE24-1/2-3	1/2	980	6219	5716	5061	2600	66	350	7178	7104	7178	7104
	RE24-3/4	RE24-3/4-3	3/4	1140	7090	6648	6144	4413	71	360	7332	7216	7332	7216
	RE24-1	RE24-1-3	1	1250	7180	6696	6271	4464	73	365	7730	7510	7730	7510
30"	RE30-1/3	RE30-1/3-3	1/3	595	7909	6380	3617	767	60	385	8041	7996	8041	7996
	RE30-1/2	RE30-1/2-3	1/2	640	8507	7170	4486	1373	64	385	8164	8090	8164	8090
	RE30-3/4	RE30-3/4-3	3/4	770	10235	9192	7657	3833	66	400	8445	8328	8445	8328
	RE30-1	RE30-1-3	1	975	10668	9959	8626	5184	70	400	8725	8503	8725	8503
36"	RE30-1 1/2	RE30-1 1/2-3	1.5	1140	12473	11867	11112	8135	77	410	8901	8570	8901	8570
	RE36-1/3	RE36-1/3-3	1/3	460	9113	6992	3722	486	64	425	9743	9697	9743	9697
	RE36-1/2	RE36-1/2-3	1/2	530	10500	8821	5985	2084	66	425	9861	9786	9861	9786
	RE36-3/4	RE36-3/4-3	3/4	605	11985	10583	8563	4017	68	435	10058	9942	10058	9942
	RE36-1	RE36-1-3	1	665	13174	11932	10299	5729	70	440	10286	10065	10286	10065
	RE36-1 1/2	RE36-1 1/2-3	1.5	720	13660	12012	9579	5000	72	440	10690	10323	10690	10323
42"	RE36-2	RE36-2-3	2	870	16554	15376	14088	9691	74	455	11487	10863	11487	10863
	RE42-1/2	RE42-1/2-3	1/2	390	12343	9352	4957	1642	65	540	10929	10853	10929	10853
	RE42-3/4	RE42-3/4-3	3/4	435	14040	11530	7633	3311	67	545	11311	11194	11311	11194
	RE42-1	RE42-1-3	1	490	15429	13194	10438	4668	69	555	11539	11319	11539	11319
	RE42-1 1/2	RE42-1 1/2-3	1.5	550	17420	15421	13117	7289	71	560	11768	11400	11768	11400
	RE42-2	RE42-2-3	2	725	20653	19128	17503	11319	74	570	12484	11863	12484	11863
48"	-----	RE42-3-3	3	830	23645	22296	20984	17290	79	585	-----	12012	-----	12012
	RE48-3/4	RE48-3/4-3	3/4	370	17339	13700	7389	2244	70	650	13265	13147	13265	13147
	RE48-1	RE48-1-3	1	410	19188	16078	10903	4037	71	660	13499	13278	13499	13278
	RE48-1 1/2	RE48-1 1/2-3	1.5	465	21731	19010	14991	7081	72	665	13705	13339	13705	13339
	RE48-2	RE48-2-3	2	520	24274	21943	19080	10125	74	680	14494	13868	14494	13868
	-----	RE48-3-3	3	680	28150	25683	23615	16930	80	700	-----	14043	-----	14043
54"	-----	RE48-5-3	5	800	33160	30900	29290	25000	83	720	-----	14155	-----	14155
	RE54-1	RE54-1-3	1	410	23130	20588	17500	9600	73	910	16063	15840	16063	15840
	RE54-1 1/2	RE54-1 1/2-3	1.5	450	25400	22600	19300	10316	75	920	16387	16019	16387	16019
	RE54-2	RE54-2-3	2	480	27200	24312	20660	11010	76	930	16800	16173	16800	16173
	-----	RE54-3-3	3	550	31213	28722	25830	15420	77	940	-----	16468	-----	16468
60"	-----	RE54-5-3	5	660	37458	35238	32893	26538	80	960	-----	16592	-----	16592
	RE60-1	RE60-1-3	1	250	23090	19161	12850	-----	76	1150	16903	16682	16903	16682
	RE60-1 1/2	RE60-1 1/2-3	1.5	340	28068	23283	15624	8000	77	1150	17551	17182	17551	17182
	RE60-2	RE60-2-3	2	390	32200	26710	17924	9380	78	1200	17935	17309	17935	17309
	-----	RE60-3-3	3	450	37183	32356	25324	15013	84	1220	-----	17611	-----	17611
60"	-----	RE60-5-3	5	540	44600	41232	35819	23237	86	1240	-----	17721	-----	17721
	-----	RE60-7 1/2-3	7.5	620	50184	47603	43981	32880	89	1285	-----	18347	-----	18347

Note: Products listed in this section are custom built and subject to 100% cancellation/restocking charges.

Direct Drive Roof Ventilators

Options

- Protective coating.
- Prefabricated curbs
- Disconnect switch



⚠ WARNING: This product can expose you to chemicals including nickel which is known to the State of California to cause cancer, and chromium, which is known to the State of California to cause birth defects and/or reproductive harm. For more information go to www.P65Warnings.ca.gov.

Features

- Cast Aluminum blades on most models
- Totally enclosed and explosion proof motors
- 1-Phase motors are field convertible 115V/230V
- 3-Phase motors are field convertible 230V/460V
- Motors are set to lower voltage at the factory unless a request is made at time of order to set them to the higher voltage
- Explosion proof motors are Class 1, Div 1, Group D and Class 2, Div 1, Groups F & G
- Wind band is 18 gauge galvanized steel
- Rubber shim under dampers for better seal
- Size of roof opening to be 6" larger than fan size
- Some models available with low R.P.M. motor for quieter operation
- 1 year limited warranty

Standard Models

BLADE SIZE	1-PHASE 115/230V	3-PHASE 208/230/460v	HP	RPM	C.F.M - STATIC PRESSURE				Db's @ 10'	WT. (LBS)	LIST			
					0"	1/8"	1/4"	1/2"			TEC		EXP*	
	MFG MODEL NUMBER		1 PH	3 PH	1 PH	3 PH								
18"	UED18-1/4	UED18-1/4-3	1/4	1140	2570	2263	1673	854	66	170	5159	5180	5508	5807
	UED18-1/3	UED18-1/3-3	1/3	1725	3375	3000	2600	1400	75	175	4773	4764	5516	5675
	UED18-1/2	UED18-1/2-3	1/2	1725	4133	3938	3724	3132	76	180	4902	4882	5652	5791
	UED18-1	UED18-1-3	1	1725	4600	4375	4080	3000	77	190	5464	5346	6228	6287
24"	UED24-1/4	UED24-1/4-3	1/4	1725	5200	4200	2820	----	75	240	5338	5363	5689	5988
	UED24-3/4	UED24-3/4-3	3/4	1140	6900	6450	6265	3300	76	260	6463	6199	7204	7146
	UED24-1	UED24-1-3	1	1725	7425	7000	6350	5000	83	280	5828	5725	6599	6671
	-----	UED24-3-3	3	1725	10500	9800	9500	8700	85	295	-----	6148	-----	7306
30"	UED30-3/4	UED30-3/4-3	3/4	1140	10440	9750	8750	6000	79	310	6766	6321	7510	7460
	-----	UED30-1-3	1	870	10800	10100	9100	6360	74	330	-----	7349	-----	-----
	UED30-1 1/2	UED30-1 1/2-3	1.5	1140	10410	9686	8834	6420	81	325	9358	6928	-----	7889
	UED30-2	UED30-2-3	2	1140	14000	13750	12900	10450	82	335	11282	7095	-----	8122
	-----	UED30-3-3	3	1725	16000	15350	14700	12900	89	335	-----	6477	-----	7642
36"	UED36-2	UED36-2-3	2	1140	17620	16500	15200	12300	84	430	12549	8407	-----	9432
	-----	UED36-3-3	3	1140	20500	19500	18500	15850	85	455	-----	8914	-----	10599
	-----	UED36-5-3	5	1140	22600	21700	20500	19000	87	465	-----	9514	-----	11413
42"	UED42-2	UED42-2-3	2	1140	17964	17277	15326	12351	88	500	13401	9277	-----	10300
	-----	UED42-5-3	5	1140	28970	27960	26840	24200	89	500	-----	10342	-----	12237
48"	-----	UED48-3-3	3	1140	28600	26500	24400	20000	92	550	-----	11165	-----	12295
	-----	UED48-5-3	5	870	33000	31500	29750	25300	86	665	-----	13327	-----	-----
	-----	UED48-7 1/2-3	7.5	1140	37000	35100	32800	28000	94	740	-----	13388	-----	15805
	-----	UED48-10-3	10	1140	41000	39200	38300	35400	95	875	-----	14093	-----	16664
60"	-----	UED60-5-3	5	870	45200	41500	37000	26000	90	940	-----	17612	-----	-----
	-----	UED60-7 1/2-3	7.5	870	47000	45500	43600	38700	92	950	-----	18841	-----	-----

Note: Products listed in this section are custom built and subject to 100% cancellation/restocking charges.

*Not all EXP motors are 208v capable.

Dimensions

SIZE	MINIMUM ROOF HOLE SIZE (SQUARE)	WIND BAND OUTER DIMENSION	ROOF CURB OUTER DIMENSION (SQUARE)	WIND BAND HEIGHT
18"	28"	24"	33"	16"
24"	34"	30"	39"	19"
30"	40"	36"	45"	22"
36"	46"	42"	51"	25"
42"	52"	48"	57"	27"
48"	58"	54"	63"	30"
60"	70"	66"	75"	42"

Belt Drive Roof Ventilators



WARNING: This product can expose you to chemicals including nickel which is known to the State of California to cause cancer, and chromium, which is known to the State of California to cause birth defects and/or reproductive harm. For more information go to www.P65Warnings.ca.gov.

Options

- Protective coating.
- Prefabricated curbs
- Disconnect switch

Features

- Standard blades are heavy gauge steel
- Totally enclosed motors.
- 1-Phase motors are field convertible 115V/230V
- 3-Phase motors are field convertible 230V/460V
- Motors are set to lower voltage at factory unless a request is made at time of order to set them to the higher voltage
- Wind band is 18 gauge galvanized steel
- Galvanized steel butterfly damper with rubber stops and seals
- Size of the roof opening to be 6" larger than fan size (Wind Band O.D.) dimension
- 1 year limited warranty.

Standard Models

BLADE SIZE	1-PHASE 115/230V	3-PHASE 208/230/460v	HP	RPM	C.F.M - STATIC PRESSURE				Db's @ 10'	WT. (LBS)	LIST	
	MFG MODEL NUMBER				0"	1/8"	1/4"	1/2"			1 PH	3 PH
					TEC							
24"	UEB24-1/3	UEB24-1/3-3	1/3	780	4900	4222	2807	800	64	300	5799	5791
	UEB24-1/2	UEB24-1/2-3	1/2	980	6219	5716	5661	2600	66	305	5973	5952
	UEB24-3/4	UEB24-3/4-3	3/4	1140	7090	6648	6144	4413	71	310	6177	6069
30"	UEB30-1/2	UEB30-1/2-3	1/2	640	8507	7170	4486	1373	64	350	6251	6228
	UEB30-3/4	UEB30-3/4-3	3/4	770	10235	9192	7657	3833	66	360	6586	6468
	UEB30-1	UEB30-1-3	1	975	10668	9959	8626	5184	70	370	7015	6948
36"	UEB36-1/2	UEB36-1/2-3	1/2	530	10500	8821	5985	2084	66	360	7386	7365
	UEB36-3/4	UEB36-3/4-3	3/4	605	11985	10583	8563	4017	68	370	7801	7685
	UEB36-1	UEB36-1-3	1	665	13174	11932	10299	5729	70	390	8091	8062
	UEB36-1 1/2	UEB36-1 1/2-3	1.5	720	13660	12012	9579	5000	72	395	8426	8290
42"	UEB42-3/4	UEB42-3/4-3	3/4	435	14040	11530	7633	3311	67	455	8501	8384
	UEB42-1	UEB42-1-3	1	490	15429	13194	10438	4668	69	465	8858	8844
	UEB42-1 1/2	UEB42-1 1/2-3	1.5	550	17420	15421	13117	7289	71	470	9382	9244
	UEB42-2	UEB42-2-3	2	725	20653	19128	17503	11319	74	485	10052	9681
	-----	UEB42-3-3	3	830	23645	22296	20984	17290	79	495	----	9819
48"	UEB48-3/4	UEB48-3/4-3	3/4	370	17339	13700	7389	2244	70	505	9832	9723
	UEB48-1	UEB48-1-3	1	410	19188	16078	10903	4037	71	520	10130	10059
	UEB48-1 1/2	UEB48-1 1/2-3	1.5	465	21731	19010	14991	7081	72	535	10306	10196
	UEB48-2	UEB48-2-3	2	520	24274	21943	19080	10125	74	545	11270	10926
	-----	UEB48-3-3	3	680	28150	25683	23615	16930	80	560	----	11109
54"	UEB54-1	UEB54-1-3	1	410	23130	20588	17500	9600	73	870	13753	13635
	UEB54-1 1/2	UEB54-1 1/2-3	1.5	450	25400	22600	19300	10316	75	880	14065	13942
	UEB54-2	UEB54-2-3	2	480	27200	24312	20660	11010	76	890	14458	14137
	-----	UEB54-3-3	3	550	31213	28722	25830	15420	80	900	----	14640
	-----	UEB54-5-3	5	660	37458	35238	32843	26538	82	920	----	14800
60"	UEB60-1 1/2	UEB60-1 1/2-3	1.5	340	28068	23203	15624	8000	78	940	14968	14844
	UEB60-2	UEB60-2-3	2	390	32200	26710	17924	9380	80	960	15296	14982
	-----	UEB60-3-3	3	450	37183	32356	25324	15013	84	985	----	15760
	-----	UEB60-5-3	5	540	44600	41232	35819	23237	86	1000	----	15907

Note: Products listed in this section are custom built and subject to 100% cancellation/restocking charges.

Dimensions

SIZE	MINIMUM ROOF HOLE SIZE (SQUARE)	WIND BAND OUTER DIMENSION	ROOF CURB OUTER DIMENSION (SQUARE)	WIND BAND HEIGHT
24"	34"	30"	39"	19"
30"	40"	36"	45"	22"
36"	46"	42"	51"	25"
42"	52"	48"	57"	27"
48"	58"	54"	63"	30"
54"	64"	60"	69"	36"
60"	70"	66"	75"	42"

Tubeaxial Direct Drive Duct Fans



Features

- Totally enclosed and explosion proof motors
- 1-Phase motors are field convertible 115V/230V
- 3-Phase motors are field convertible 230V/460V
- Motors are set to lower voltage at the factory unless a request is made at time of order to set them to the higher voltage
- Explosion proof motors are Class 1, Div 1, Group D and Class 2, Div 1, Groups F & G
- 14 gauge steel drum including mounting flanges
- Fan can be mounted to operate in any position
- Rugged cast aluminum blade, non-sparking
- 1 year limited warranty

Dimensions

SIZE	HOUSING INNER DIM.	HOUSING OUTER DIM.	BOLT HOLE CENTERS	HOUSING DEPTH
12"	12"	14"	13 1/8"	14"
18"	18"	20"	19 1/8"	14"
24"	24"	27"	25 3/4 "	18"
27"	27"	30"	28 3/4"	18"
30"	30"	33"	31 3/4"	18"
34"	34"	37"	35 3/4"	18"
42"	42"	45"	43 9/16"	18"
48"	48"	51"	49 5/8"	18"

⚠ WARNING: This product can expose you to chemicals including nickel which is known to the State of California to cause cancer, and chromium, which is known to the State of California to cause birth defects and/or reproductive harm. For more information go to www.P65Warnings.ca.gov.

Options

- Companion flanges
- Fan guards
- Protective coating
- Access doors

Standard Models

BLADE SIZE	1-PHASE 115/230V	3-PHASE 230/460v	HP	RPM	BLADES	C.F.M - STATIC PRESSURE				Db's @ 10'	WT. (LBS)	LIST			
						MFG MODEL NUMBER						TEC		EXP	
						0"	1/4"	1/2"	3/4"			1 PH	3 PH	1 PH	3 PH
12"	TXD12-1/4	TXD12-1/4-3	1/4	1725	4	1180	520	----	----	77	40	1846	1827	2296	2373
	TXD12-1/2	TXD12-1/2-3	1/2	3450	4	1875	1400	1250	1100	82	45	1898	1892	2565	2853
	TXD12-3/4	TXD12-3/4-3	3/4	3450	6	2044	1920	1650	1500	83	45	1969	1969	2738	2949
18"	TXD18-1/4	TXD18-1/4-3	1/4	1725	4	3450	2500	----	----	74	55	2181	2161	2628	2704
	TXD18-1/3	TXD18-1/3-3	1/3	1725	6	3375	2600	1400	----	75	65	2289	2308	2871	3033
	TXD18-1/2	TXD18-1/2-3	1/2	1725	6	4150	3150	1700	----	77	65	2378	2390	3072	3001
	TXD18-1	TXD18-1-3	1	1725	6	4600	4080	3000	2100	80	70	2681	2550	3346	3403
24"	TXD24-1/4	TXD24-1/4-3	1/4	1725	2	5200	2820	----	----	80	95	2390	2378	2841	2858
	TXD24-1/3	TXD24-1/3-3	1/3	1140	6	4975	4250	2850	----	74	110	2878	2924	3845	3904
	TXD24-1/2	TXD24-1/2-3	1/2	1725	4	6510	5200	3100	1800	80	115	2643	2655	3334	3263
	TXD24-3/4	TXD24-3/4-3	3/4	1140	6	6900	6265	3300	----	74	125	3569	3174	4135	4005
	TXD24-1	TXD24-1-3	1	1725	6	7425	6350	5000	3300	82	120	2929	2795	3596	3655
	TXD24-2	TXD24-2-3	2	1725	6	9525	8810	7980	6960	84	120	3546	3019	4940	4010
27"	TXD27-1/2	TXD27-1/2-3	1/2	1725	4	7550	6000	4000	2000	86	125	2886	2891	3569	3498
	TXD27-1	TXD27-1-3	1	1725	4	9600	8400	7050	4800	86	155	3127	3001	3794	3852
	TXD27-2	TXD27-2-3	2	1725	6	11500	10700	9300	8000	86	165	3813	3289	5209	4281
	TXD30-1/2	TXD30-1/2-3	1/2	1725	4	8980	6300	4350	2300	86	130	3001	3013	3693	3622
30"	TXD30-3/4	TXD30-3/4-3	3/4	1140	6	10440	8750	6000	----	80	150	4033	3634	4601	4485
	TXD30-2	TXD30-2-3	2	1725	6	12000	10450	8700	6000	89	155	3923	3397	5319	4389
	-----	TXD30-3-3	3	1725	6	16000	14700	12900	10200	89	175	----	3551	----	4614
34"	TXD34-1 1/2	TXD34-1 1/2-3	1.5	1725	4	13350	10000	7300	----	88	175	4033	3865	5863	4852
	TXD34-2	TXD34-2-3	2	1725	4	14850	12100	8800	4000	89	200	4466	3942	5863	4936
	-----	TXD34-3-3	3	1140	3	19300	17230	14800	11614	86	250	----	5106	----	6447
	-----	TXD34-5-3	5	1725	6	21000	18900	17500	14850	91	220	----	4197	----	5365
36"	TXD36-2	TXD36-2-3	2	1140	6	17620	15200	12300	8500	84	210	----	4377	----	5519
	-----	TXD36-3-3	3	1725	4	18500	15700	13900	11500	89	230	----	4871	----	6209
42"	-----	TXD42-1-3	1	870	4	15800	13480	5800	900	81	270	----	5293	----	----
	TXD42-2	TXD42-2-3	2	1140	4	17964	15326	12351	7600	87	260	----	4986	----	6119
	-----	TXD42-3-3	3	1140	4	24500	23000	19650	14000	87	260	----	5587	----	6927
	-----	TXD42-5-3	5	1140	4	28970	26840	24200	19500	87	300	----	5793	----	7709
48"	-----	TXD48-3-3	3	1140	4	28600	24400	20000	15900	94	290	----	6966	----	8304
	-----	TXD48-5-3	5	870	4	33000	29750	25300	18000	86	500	----	8856	----	----

Duct Fan Guards

Features

- Enamel finish
 - Can be used as front or rear guards.
- (Rear guard for TXD models must be ordered with fan)

⚠ WARNING: This product can expose you to chemicals including nickel which is known to the State of California to cause cancer, and chromium, which is known to the State of California to cause birth defects and/or reproductive harm. For more information go to www.P65Warnings.ca.gov.

Standard Models

FAN SIZE	MFG MODEL	LIST	FAN SIZE	MFG MODEL	LIST
12"	TXG-12	158	30"	TXG-30	215
15"	TXG-15	158	34"	TXG-34	274
18"	TXG-18	158	36"	TXG-36	283
24"	TXG-24	172	42"	TXG-42	311
27"	TXG-27	215	48"	TXG-48	406

Note: Products listed in this section are custom built and subject to 100% cancellation/restocking charges.

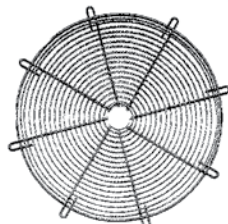

Tubeaxial Belt Drive Duct Fans



WARNING: This product can expose you to chemicals including nickel which is known to the State of California to cause cancer, and chromium, which is known to the State of California to cause birth defects and/or reproductive harm. For more information go to www.P65Warnings.ca.gov.

Features

- Eliminates fumes and vapors from paint spray booths and other hazardous areas
- Totally enclosed and explosion proof motors
- 1-Phase motors are field convertible 115V/230V
- 3-Phase motors are field convertible 230V/460V
- Motors are set to lower voltage at the factory unless a request is made at time of order to set them to the higher voltage
- Explosion proof motors are Class 1, Div 1, Group D and Class 2, Div 1, Groups F & G
- Recommended for most paint spray applications because motor is out of air
- 14 gauge steel drum including mounting flanges at each end
- Completely enclosed belt and ball bearing housing
- Adjustable motor base for proper belt tension
- Rugged cast aluminum blade, non-sparking
- Fan can be mounted to operate in any position
- 1 year limited warranty

Options

- Companion flanges
- Protective coating
- Access doors
- Belt guards
- Motor covers
- Fan guards

Standard Models

BLADE SIZE	1-PHASE 115/230V-60Hz	3-PHASE 230/460v-60Hz	HP	RPM	BLADES	C.F.M. - STATIC PRESSURE				Db's @10'	WT (LBS)	LIST			
						MFG MODEL NUMBER						TEC		EXP	
						0"	1/4"	1/2"	3/4"			1 PH	3 PH	1 PH	3 PH
12"	TXB12-1/4	TXB12-1/4-3	1/4	2625	4	1444	1033	380	----	77	62	2489	2475	2957	3034
	TXB12-1/3	TXB12-1/3-3	1/3	2875	4	1586	1135	415	----	78	65	2539	2566	3149	3309
	TXB12-1/2	TXB12-1/2-3	1/2	3450	4	1875	1400	1250	1100	83	65	2539	2539	3129	3393
	TXB12-3/4	TXB12-3/4-3	3/4	3450	6	2044	1920	1650	1500	83	67	2765	2765	3342	3585
15"	TXB15-1/4	TXB15-1/4-3	1/4	2000	6	2600	1700	----	----	77	67	2739	2727	3205	3283
	TXB15-1/3	TXB15-1/3-3	1/3	2200	6	2950	2100	1000	----	78	69	2821	2843	3425	3585
	TXB15-1/2	TXB15-1/2-3	1/2	1890	6	3350	2650	1500	----	76	75	2905	2918	3623	3547
	TXB15-3/4	TXB15-3/4-3	3/4	2200	6	3900	3400	2700	1150	78	85	3161	2995	3879	3700
18"	TXB18-1/4	TXB18-1/4-3	1/4	1600	6	3050	2000	----	----	76	80	2892	2880	3360	3437
	TXB18-1/3	TXB18-1/3-3	1/3	1725	6	3375	2600	1400	----	77	85	2925	2969	3552	3713
	TXB18-1/2	TXB18-1/2-3	1/2	1890	6	3850	3100	2000	----	78	95	3034	3047	3751	3674
	TXB18-1	TXB18-1-3	1	1725	6	4600	4080	3000	2100	77	105	3461	3302	4121	4187
24"	TXB18-1 1/2	TXB18-1 1/2-3	1.5	1990	6	5350	4830	3950	3000	80	105	3623	3455	5516	4477
	TXB24-1/2	TXB24-1/2-3	1/2	1298	6	5643	4826	3500	----	78	120	3290	3302	4006	3929
	TXB24-3/4	TXB24-3/4-3	3/4	1600	6	6906	5900	4650	2750	80	130	3592	3425	4308	4129
	TXB24-1	TXB24-1-3	1	1725	6	7425	6350	5000	3300	84	140	3623	3482	4308	4373
	TXB24-1 1/2	TXB24-1 1/2-3	1.5	1540	6	8200	7650	6850	5500	81	145	4404	4237	6289	5256
	TXB24-2	TXB24-2-3	2	1600	6	9760	8830	8090	7000	82	170	5008	4469	6441	5487
27"	-----	TXB24-3-3	3	1725	6	10500	9500	8700	7800	86	190	-----	4609	-----	5707
	TXB27-3/4	TXB27-3/4-3	3/4	1250	6	8330	7550	6500	4650	78	150	4399	4225	5109	4937
	TXB27-1	TXB27-1-3	1	1400	6	9400	8480	7300	5200	82	155	4425	4289	5109	5168
	TXB27-1 1/2	TXB27-1 1/2-3	1.5	1600	6	10700	9700	8375	6000	84	170	4625	4455	6506	5467
30"	TXB27-2	TXB27-2-3	2	1350	6	11500	10700	9300	8000	81	210	5155	4615	6597	5642
	TXB30-1/2	TXB30-1/2-3	1/2	1140	4	8900	6660	2300	----	79	140	4159	4182	4878	4809
	TXB30-1	TXB30-1-3	1	1298	6	9867	7980	4120	----	82	150	4615	4482	5301	5367
	TXB30-1 1/2	TXB30-1 1/2-3	1.5	1035	6	11100	9700	7500	3500	78	165	4815	4647	6700	5668
	TXB30-2	TXB30-2-3	2	1176	6	12100	11000	9322	6700	81	215	5269	4731	6711	5757
	-----	TXB30-3-3	3	1350	6	13480	12498	11465	10380	84	215	-----	5046	-----	6134
34"	-----	TXB30-5-3	5	1650	6	16440	15242	13982	12659	88	230	-----	5103	-----	6296
	TXB34-1 1/2	TXB34-1 1/2-3	1.5	1170	6	13695	11100	6000	1015	82	190	5565	5400	7450	6411
	TXB34-2	TXB34-2-3	2	1027	6	14657	12590	10000	8000	81	240	6199	5661	7635	6685
	-----	TXB34-3-3	3	1175	6	17580	15896	14095	12000	85	260	-----	5809	-----	6898
42"	-----	TXB34-5-3	5	1416	6	20500	19000	17500	16000	88	305	-----	5847	-----	7051
	TXB42-1 1/2	TXB42-1 1/2-3	1.5	750	4	18960	14662	7200	----	78	250	6597	6629	8680	7642
	TXB42-2	TXB42-2-3	2	820	4	20700	17002	11400	4000	80	260	7062	6738	8719	7758
	-----	TXB42-3-3	3	890	4	23700	20200	16970	9950	82	260	-----	6877	-----	7967
	-----	TXB42-5-3	5	850	6	26900	24403	22250	18400	82	270	-----	7237	-----	8437
48"	-----	TXB48-5-3	5	800	6	33000	29000	25600	20000	85	375	-----	10729	-----	11930
	-----	TXB48-7 1/2-3	7.5	900	6	37000	34500	31000	27000	87	520	-----	11396	-----	13417

Dimensions

SIZE	HOUSING INNER DIMENSION	HOUSING OUTER DIMENSION	BOLT HOLE CENTERS	HOUSING DEPTH
12"	12"	14"	13 1/8"	12"
15"	15"	17"	16 1/8"	12"
18"	18"	20"	19 1/8"	12"
24"	24"	27"	25 3/4"	12" & 16"
27"	27"	30"	28 3/4"	16"
30"	30"	33"	31 3/4"	16"
34"	34"	37"	35 3/4"	16"
42"	42"	45"	43 3/16"	18"
48"	48"	51"	49 3/8"	24"

Note: Products listed in this section are custom built and subject to 100% cancellation/restocking charges.

Power Attic Mount Dome Ventilator



WARNING: This product can expose you to chemicals including nickel which is known to the State of California to cause cancer, and chromium, which is known to the State of California to cause birth defects and/or reproductive harm. For more information go to www.P65Warnings.ca.gov.

Features

- 120V Motor / 1-Phase
- Automatic thermostat (60°-120°F)
- Insect and bird screen installed
- Black or brown painted finish or mill finish

Note: Photograph is a representation of stocked models. Actual model may vary in appearance.

Standard Models

MFG CATALOG NUMBER	MFG MODEL NUMBER	DOMES COLOR	SPEED	CFM .03 SP	VOLTS	HP	RPM	ATTIC SIZE / SQ. FT.*	WT. (LBS)	LIST
08664202	PDV-305-1MB-GY-G	Mill	1	1000	120	1/12	1050	Average/1600	19	197
08664302	PDV-305-1MB-BR-G	Brown	1	1000	120	1/12	1050	Average/1600	19	
08664402	PDV-305-1MB-BLK-G	Black	1	1000	120	1/12	1050	Average/1600	19	

*@ 4:12 Pitch Roof

Gable Exhaust Fan



Damper requires 16 1/2 x 16 1/2 opening



WARNING: This product can expose you to chemicals including nickel which is known to the State of California to cause cancer, and chromium, which is known to the State of California to cause birth defects and/or reproductive harm. For more information go to www.P65Warnings.ca.gov.

Features

- 120V motor / 1-Phase
- Automatic adjustable thermostat (60°-120°F)
- Partially assembled (mounting tabs must be assembled)
- 14" blade diameter
- 4 mounting tabs on 16" centers

Standard Models

MFG CATALOG NUMBER	MFG MODEL NUMBER	DESCRIPTION	CFM .03 SP	ATTIC SIZE/ SQ. FT.*	WT. (LBS)	LIST
08663702	GV-405-2B-G	Gable Mount Ventilator	1540	Average/2400	13	153
08665202	AGD-1616B-G	White Aluminum Damper for GV-405-2	----	----	3	89

*@ 4:12 Pitch Roof

Belt Drive Wholehouse Fans

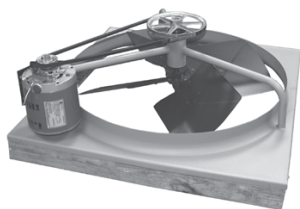

WARNING: This product can expose you to chemicals including nickel which is known to the State of California to cause cancer, and chromium, which is known to the State of California to cause birth defects and/or reproductive harm. For more information go to www.P65Warnings.ca.gov.

Features

- 120V, 1-Phase, 2-Speed motors
- Shutters automatically open when fan is turned on and close tightly when fan is turned off
- Made in U.S.A.

NOTE: Belt Drive Fan with "No Joist Cut" Shutter.

Standard Models

MFG CATALOG NUMBER	MFG MODEL NUMBER	SIZE	SPEED	MOTOR HP	CFM @ .1 IN. H2O PRESSURE DROP w/ SHUTTER	FAN SPEED RPM	FAN MOUNTING DIMENSIONS (IN)			EXHAUST SQ. FT. REQ'D	AMPS	WT. (LBS)	LIST
							A	B	C				
07936202	BD24-2-WHS	24"	2	1/3	4500/2700	612/410	28	29.5	14.5	7	5.7/4.8	40	892
07936302	BD30-2-WHS	30"	2	1/3	7600/5800	520/350	34	35.5	14.5	9	6.9/5.5	50	959
07936402	BD36-2-WHS	36"	2	1/3	9675/6400	395/265	40	41.5	14.5	12	6.3/3.1	64	1054

Fan Dimensions

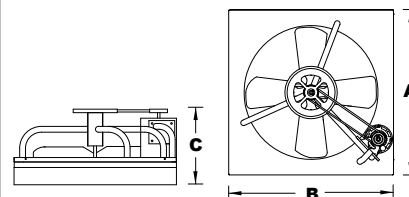

Ceiling Shutters

MFG CATALOG NUMBER	MFG MODEL NUMBER	FIT HOLE SIZE (I.D.)	OUTSIDE SIZE (O.D.)	FAN SIZE	WT. (LBS)	LIST
07944802	CS-10-W	26X26	28X28	24"	8	158
07944602	CS-13-W	32X34	34X36	30"	10	165
07945302	CS-14-W	34X34	36X36	30"	10	173
07944702	CS-18-W	32X43	34X45	36"	11	188
07945202	CS-19-W	34X43	36X45	36"	11	203

"Joist out style" (For replacement only)

Control Options

MFG CATALOG NUMBER	MFG MODEL NUMBER	DESCRIPTION	WT. (LBS)	LIST
07927002	2-SW	2 Speed wall switch & plate	1	45
05000802	1A22-7	SP Close on rise (Attic Thermostat) (80°-130°F)	1	53

WARNING: This product can expose you to chemicals including nickel which is known to the State of California to cause cancer, and chromium, which is known to the State of California to cause birth defects and/or reproductive harm. For more information go to www.P65Warnings.ca.gov.

Portable Utility Lights

4 Styles of Light Sources



LED 37

- 30,000+ hour lamp life
- Safety glass front lens cover
- NEMA 4 rated enclosure
- Compliant with RoHS 2 Directive (2011/65/EU).

LED 1 & 2

- Longest Lamp Life
- Lowest energy usage per lumens produced.
- 18 Watt LED bulbs (included)
- Shade remains Cool-to-the-Touch.

Fluorescent

- Uses compact, low energy use
- Long life 55 Watt Fluorescent bulbs (included)
- Shade remains Cool-to-the-Touch.

Quartz Halogen

- High light output
- Weatherproof aluminum die-cast light heads
- 500 Watt quartz bulbs (included)

6 Types of Bases and Mounts

Pedestal Base



- 16 gauge round steel tube construction
- Height adjustable from 5'-6" to 8'-6" high
- 18" heavy duty steel base

Cart Base



- 16 gauge round steel tube construction
- Height adjustable from 5' to 8' high
- 10" diameter wheels

Tripod Base

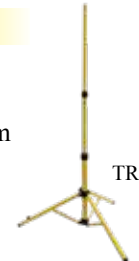

- 20 gauge round steel tube construction
- Height adjustable from 3' to 6'-6" high
- Base covers 46" diameter area

Floor Base



- 12 gauge steel base
- Handle included
- Base covers 16" diameter area

Clamp-On Mount



- Clamp secures light head to most surfaces up to 3"

Magnet Mount



- 210 lb. magnetic strength
- 1/4" steel arm
- Extends 6" from mounting surface

Light Selection Chart & Illumination Levels

LIGHT SOURCE:	QUARTZ HALOGEN		FLUORESCENT		LED		LED 37		
	1	2	1	2	1	2	1	2	
# OF LIGHT HEADS	1	2	1	2	1	2	1	2	
MAX. WATTAGE	500	1,000	55	110	18	36	37	74	
MAX. LUMENS	11,000	22,000	3,000	6,000	1,550	3,100	3,680	7,360	
AVG. BULB LIFE (HRS.)	2,000		10,000		25,000		>30,000		
WIRE GUARD INCLUDED	Yes		Yes		Yes		No		
BULB INCLUDED	Yes		Yes		Yes		Yes		
LIGHT SOURCE ILLUMINATION LEVELS									
Measured Footcandles & Distance from Light Source (open area)	5' ft.	74.4	137.3	20.0	35.8	224.5	456.8	448.1	896
	10' ft.	36.1	65.9	8.7	14.8	121.4	258.8	299	598
	20' ft.	13.2	24.6	3.1	5.1	29.0	64.0	71	142
	30' ft.	6.6	12.3	1.7	2.5	14.2	31.4	34	68

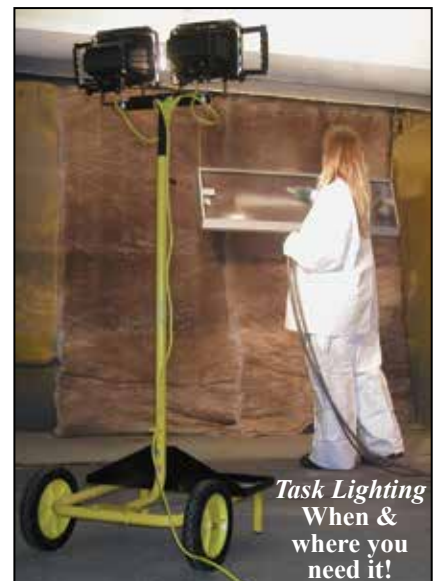

Task Lighting
When & where you need it!

ATTENTION

Fluorescent and HID lamps contain mercury. Dispose of these lamps according to local, state, or federal laws. For further information on local, state, or other requirements for disposal of mercury-containing lamps, see <http://www.lamprecycle.com>.

Incandescent, Fluorescent, and LED Series

Features

- Chip resistant safety yellow & black powder coating finish for high visibility and durability
- 15' long 18/3 SJT, 120V cordset with NEMA 15-5 grounded plug
- Shade will swivel 300° horizontally and 210° vertically
- On/Off switch, bulb, and wire guard included on each light head
- Made in U.S.A. with domestic and foreign components

Lamp Specifications - LED & FL

- Aluminum shade is 9 3/8" long with 7 3/4" diameter opening and will swivel 300° horizontally and 210° vertically
- LED 1 & 2 models are constructed with narrow 25° angle beam generating 1,550 lumens per bulb.
- FL models include a 55W spiral fluorescent bulb and internal reflector for maximum illumination at shorter distances.
- ETL C/US Listed for indoor & semi-protected outdoor use

Lamp Specifications - LED-37

- Lexan housing
- Safety glass front lens cover
- NEMA 4 rated enclosure
- Push button on-off switch
- 15' power cord
- Compliant with RoHS 2 Directive (2011/65/EU), that of which includes the application exemptions outlined in Annex III of the directive.



Lamp Specifications - QH

- QH models include a 500 Watt quartz halogen bulb and weatherproof die cast aluminum light head with impact resistant lens
- Each shade size is 9" wide x 7 1/4" high x 9 3/4" deep
- ETL C/US listed for indoor & semi-protected outdoor use



Standard Models

MFG CATALOG NUMBER	MFG MODEL NUMBER	TYPE	DESCRIPTION	TOTAL MAX WATTS	NUMBER OF LIGHT HEADS	WT. (LBS)	LIST
04885402	LED-37-1	LIGHTHEAD	LED	37	1	6	378
04885302	LED-37-2			74	2	10	766
04873602	LED-1		LED	18	1	6	322
04873702	LED-2			36	2	9	716
04803002	FL-1	LIGHTHEAD	FLUORESCENT	55	1	5	229
04803402	FL-2			110	2	8	572
04802902	QH-1	LIGHTHEAD	QUARTZ HALOGEN	500	1	5	144
04803302	QH-2			1000	2	10	242
04802702	PED	MOUNT / BASE	PEDESTAL	----	----	31	316
04802802	CRT		CART	----	----	27	275
04802302	TRI		TRIPOD	----	----	9	110
04802602	FLR		FLOOR	----	----	4	89
04802402	CLP		CLAMP	----	----	2	49
04802502	MAG		MAGNET	----	----	3	59

⚠ WARNING: This product can expose you to chemicals including nickel which is known to the State of California to cause cancer, and chromium, which is known to the State of California to cause birth defects and/or reproductive harm. For more information go to www.P65Warnings.ca.gov.

Individual Portable Light Components - Replacement Bulbs

⚠ WARNING: This product can expose you to chemicals including nickel which is known to the State of California to cause cancer, and chromium, which is known to the State of California to cause birth defects and/or reproductive harm. For more information go to www.P65Warnings.ca.gov.

MFG CATALOG NUMBER	MFG MODEL NUMBER	DESCRIPTION	WATTS	USED WITH	WT. (LBS)	LIST
04850502	SSE-55	Fluorescent Bulb	55	ALL FL Light heads	1	60
04708502	LED-12	LED Bulb	18	ALL LED Light heads	1	122

LED Light Head with Mount

⚠ WARNING: This product can expose you to chemicals including nickel which is known to the State of California to cause cancer, and chromium, which is known to the State of California to cause birth defects and/or reproductive harm. For more information go to www.P65Warnings.ca.gov.



Cannot be used with clamp-on mount

M-LED-37-1

F-LED-37-1

MFG CATALOG NUMBER	MFG MODEL NUMBER	DESCRIPTION	WATTS	WT. (LBS)	LIST
04888602	M-LED-37-1	LED with Magnet Mount	37	8	468
04888402	F-LED-37-1	LED with Floor Mount	37	9	437

Heavy Duty Portable Utility Lights



PUL-1000Q-CD

Quartz Halogen Light Heads

- (2) 500 Watt weatherproof die cast Aluminum light heads with 15' long, 3-conductor cord, and plug
- Quartz halogen lamps
- Impact resistant lens
- On-Off switch
- OSHA approved wire guards and bulb included with each light head
- Made in U.S.A. with domestic and foreign components.

WARNING: This product can expose you to chemicals including nickel which is known to the State of California to cause cancer, and chromium, which is known to the State of California to cause birth defects and/or reproductive harm. For more information go to www.P65Warnings.ca.gov.



PUL-1000Q-TC

Cart Light Stand With GFCI Features

- Upright adjust from 5' to 8' high
- 10" diameter rubber wheels
- 15' all-weather, water and oil resistant SJTW 18/3 cordset and molded NEMA 5-15 plug
- Weatherproof electrical box with a 15 Amp GFCI duplex receptacle

Tripod Light Stand Features

- Square 12 gauge steel tubing construction
- Adjustable legs fold up for storage, fold flat for sand bagging or can be set and locked at 6", 12", 18", or 24" ground clearances
- Height adjustable from 5' to 11' high
- Safety stop mechanism, at full extension, prevents the mast from being pulled out of the base
- 15' all-weather, water and oil resistant SJTW 18/3 cordset and molded NEMA 5-15 plug

Standard Models

MFG CATALOG NUMBER	MFG MODEL NUMBER	BASE TYPE	BULBS	WATTS	VOLTS	MAX LUMENS	AVE. BULB LIFE (HRS)	WT. (LBS)	LIST
04467802	PUL-1000Q-CD	CART	500W Quartz Halogen	1000	120	22,000	2,000	50	769
04468302	PUL-1000Q-TC	TRIPOD						41	811
04843102	TRI-HD	Heavy Duty Tri-Pod Sold Separately. Will Accommodate all TPI Light Heads.							540

Commercial Duty Portable Utility Lights

CL 300 (Clamp on Model)



WARNING: This product can expose you to chemicals including nickel which is known to the State of California to cause cancer, and chromium, which is known to the State of California to cause birth defects and/or reproductive harm. For more information go to www.P65Warnings.ca.gov.

Features

- Ceramic socket will accept incandescent bulbs A-19, R-40 or PAR bulbs up to 300 Watt. Fixture will also accept infrared heat lamps up to 250 Watts
- LED bulb included
- 8' long - 18/3 SPT cordset with NEMA 5-15 plug
- Imported to TPI specifications.

Standard Models

MFG CATALOG NUMBER	MFG MODEL NUMBER	BASE TYPE	DESCRIPTION	MAX. WATTS	VOLTS	MAX LUMENS	AVE. BULB LIFE HOURS	WT. (LBS)	LIST
02804900	CL-300	CLIP-ON	LED	11	120	800	25,000	3	81

CL-300 is shipped in ONE carton. LED bulb included.



DKL-40VA-ARM shown with LED-1 lighthouse



WARNING: This product can expose you to chemicals including nickel which is known to the State of California to cause cancer, and chromium, which is known to the State of California to cause birth defects and/or reproductive harm. For more information go to www.P65Warnings.ca.gov.

Light Head Features

- Chip resistant safety yellow & black powder coating finish for high visibility and durability
- 5' long 18/3 SJT, 120V cordset with NEMA 15-5 grounded plug
- On/Off switch & wire guard included on each light head
- 1 1/2" square, 11-gauge, steel tubing
- 3" x 5" x 3/16" mounting plate attached with (4) 3/8" bolts (not supplied)
- (4) Lighting Sources to select from: incandescent, quartz halogen, LED, or fluorescent
- (2) Arm Lengths: 40" or 60" (plus 25" flex arm, incandescent only)
- VA models include (2) dock arms with a vertical adjustment bracket allowing outer arm to adjust from 300° horizontally and 210° vertically
- All light heads will swivel 300°
- Bulbs included with all light heads, except incandescent models
- ETL C/US Listed for indoor applications only, except QH models are semi-protected outdoor
- Made in U.S.A. with domestic and foreign components

Light Selection Chart & Illumination Levels

DESCRIPTION	Incandescent	Quartz Halogen	LED	LED 37	Fluorescent	
MAX. WATTAGE	300	500	18	37	55	
MAX. LUMENS	3,700	11,000	1,550	2,373	3,000	
AVG. BULB LIFE (HRS.)	2,000	2,000	25,000	30,000	10,000	
BULB INCLUDED	No	Yes	Yes	Yes	Yes	
LIGHT SOURCE ILLUMINATION LEVELS						
Measured Footcandles & Distance from Light Source (inside trailer)	10' ft.	15	28	121	299	9
	20' ft.	5	14	29	71	3
	30' ft.	3	8	14	34	2
	40' ft.	2	5	4	9	---
	50' ft.	---	3	3	8	---

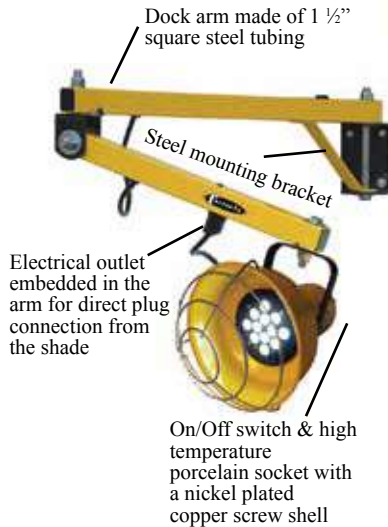

Dock Light Performance Testing

We measured light levels (in footcandles) inside a 8' x 9' x 53' trailer with a wooden floor and ceiling and white fiberglass walls. A matrix of nine measurements were taken at five work plains inside the trailer. Averages were figured along the center work plane of the trailer.

These charts measure the overall quality of truck trailer illumination from a selection of light sources. Many other factors such as: cost of energy, safety, availability of fixtures, cost of labor and replacement lamps should figure into your final decision.

Light Source and Color Characteristics	10 ft.	20 ft.	30 ft.	40 ft.	50 ft.
12W LED (Cool White)	121	29	14	3.7	3.2
37W LED (Cool White)	299	71	34	9	8
500W Quartz Halogen (Bright White)	28	14	8	5.3	3.1
300W Incandescent (Off White)	15	5	3	2.1	---
55W Fluorescent (Bright White)	9	3	2	---	---

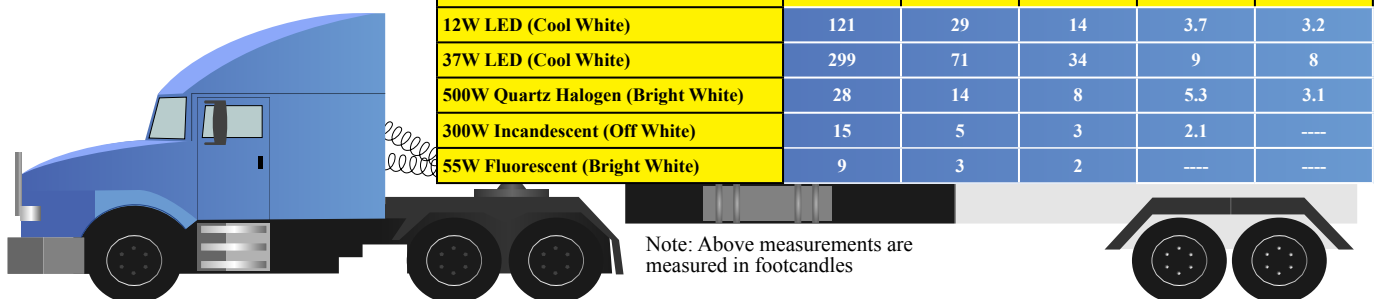

Note: Above measurements are measured in footcandles

Loading Dock Lights - Fully Assembled Standard Duty Loading Dock Arms

(Light Head and Arm Bolted Together and Shipped in One Carton)

Standard Models (120 V)

Incandescent
(Bulb not included)



Quartz



WARNING: This product can expose you to chemicals including nickel which is known to the State of California to cause cancer, and chromium, which is known to the State of California to cause birth defects and/or reproductive harm. For more information go to www.P65Warnings.ca.gov.



Fluorescent

MFG CATALOG NUMBER	MFG MODEL NUMBER	ARM LENGTH	# OF ARMS	MAX WATTS	WT. (LBS)	LIST
INCANDESCENT						
04466502	DKL-40VA	40"	2	300	14	224
04466602	DKL-60VA	60"	2		17	269
QUARTZ HALOGEN						
04467102	DKL-40VA-QH	40"	2	500	15	269
04467202	DKL-60VA-QH	60"	2		18	312
LED						
04708302	DKL-40VA-LED	40"	2	12	15	345
04708402	DKL-60VA-LED	60"	2		18	367
FLUORESCENT						
04850302	DKL-40VA-FL	40"	2	55	15	339
04850402	DKL-60VA-FL	60"	2		18	367

Note: Made in U.S.A. with domestic and foreign components

Ceiling Mounted Incandescent Flex Arm



WARNING: This product can expose you to chemicals including nickel which is known to the State of California to cause cancer, and chromium, which is known to the State of California to cause birth defects and/or reproductive harm. For more information go to www.P65Warnings.ca.gov.

Features

- Flexible elastomer arm moves when hit and then returns light to original position
- Ceramic socket will accept incandescent bulbs, R-40 or PAR bulbs up to 300W
- On-off toggle switch on light head

Standard Models

MFG CATALOG NUMBER	MFG MODEL NUMBER	ARM LENGTH	WATTS	VOLTS	MAX LUMENS	AVE. BULB LIFE (HRS)	WT. (LBS)	LIST
03854002	DKL-25-FLX	25"	300	120	3,700	2000	7	237

*Bulb not included.

Light Head Accessories

Standard Models



DLGS



LG-1

MFG CATALOG NUMBER	MFG MODEL NUMBER	DESCRIPTION	WATTS	USED WITH	WT. (LBS)	LIST
03313222	LG-1	Lamp Guard	-	INC, LED, or FL Fixtures	2	43
04887402	DLGS	Light Head Guard (Small)	-	LED-37	.5	50
04887502	DLGL	Light Head Guard (Large)	-	LED, FL, QH	1	62
04850502	SSE-55	Fluorescent Bulb	55	ALL FL Light Heads	1	60
04708502	LED-12	LED Bulb	12	ALL LED Light Heads	1	122
03105901	N/A	QH Bulb	500	QH Light Heads	.03	60

Note: Lamp guards are included with every dock light fixture.

DLGS is shown with QH light head and 24" dock arm (sold separately)

WARNING: This product can expose you to chemicals including nickel which is known to the State of California to cause cancer, and chromium, which is known to the State of California to cause birth defects and/or reproductive harm. For more information go to www.P65Warnings.ca.gov.

Loading Dock Lights - Modular

Modular Lights



WARNING: This product can expose you to chemicals including nickel which is known to the State of California to cause cancer, and chromium, which is known to the State of California to cause birth defects and/or reproductive harm. For more information go to www.P65Warnings.ca.gov.

Features

- 14" long, 18/3 conductor cord plugs into electrical junction box on arm
- On/Off switch & wire guard included with each light head
- Bulb included with all light heads except DKL-INC
- Imported to TPI specifications.
- DKL-LED-37 is compliant with ROHS 2 Directive (2011/65/EU), that of which includes the application exemptions outlined in Annex III of the directive.

Standard Models

MFG CATALOG NUMBER	MFG MODEL NUMBER	LIGHT HEAD TYPE	MAX WATTS	MAX LUMENS	AVE. BULB LIFE (HRS)	WT. (LBS)	LIST
04465602	DKL-INC	Incandescent	300	3,700	2,000	5	89
04465702	DKL-QH	Quartz Halogen	500	11,000	2,000	6	133
04708602	DKL-LED	LED	12	960	50,000	7	205
04881302	DKL-LED-37	LED	37	2,373	>30,000	5	356
04843302	DKL-FL	Fluorescent	55	3,000	10,000	7	206

Mounting Arms



The outer arm on 40VA & 60VA arms will swing 300° in horizontal plane & 210° in vertical plane



WARNING: This product can expose you to chemicals including nickel which is known to the State of California to cause cancer, and chromium, which is known to the State of California to cause birth defects and/or reproductive harm. For more information go to www.P65Warnings.ca.gov.

Features

- 1 1/2" square, 11 gauge, steel tubing
- 3" x 5" x 3/16" mounting plate attaches with (4) 3/8" bolts
- 5' long, 18/3 SJTW conductor cord and NEMA 5-15 grounded plug
- Made in U.S.A.

Standard Models

MFG CATALOG NUMBER	MFG MODEL NUMBER	ARM LENGTH	TOTAL # OF ARMS	WT. (LBS)	LIST
04465402	DKL-40VA-ARM	40"	2	18	139
04465502	DKL-60VA-ARM	60"	2	24	176
04465302	24-LDA	24"	1	11	109
04466102	40-LDA**	40"	3	18	188
04466202	60-LDA**	60"	3	24	218

**Indicates heavy duty dock arms (Horizontal swing only, no vertical movement)

Loading Dock Arm Fan



WARNING: This product can expose you to chemicals including nickel which is known to the State of California to cause cancer, and chromium, which is known to the State of California to cause birth defects and/or reproductive harm. For more information go to www.P65Warnings.ca.gov.

Features

- 18" high velocity circulator, with 3 speed, 1/8 HP, 115V, 1phase permanently lubricated, totally enclosed, PSC motor
- Modular fan plugs into electrical outlet on arm
- Coated steel guards and aluminum blades.
- Imported to TPI specifications.

Standard Models

MFG CATALOG NUMBER	MFG MODEL NUMBER	CFM			AMPS HIGH	WT. (LBS)	LIST
		HIGH	MED	LOW			
07971802	LDF-18-TE	1800	1500	1300	2.2	20	216

Note: Must be used with LDA (Heavy Duty) mounting arms.

Machine Tool Lights

Water Resistant Fluorescent Tube Lights



Remote Ballast with Cordset



Internal Ballast with Cordset



Remote Ballast



LED 29"



LED 21"

WARNING: This product can expose you to chemicals including nickel which is known to the State of California to cause cancer, and chromium, which is known to the State of California to cause birth defects and/or reproductive harm. For more information go to www.P65Warnings.ca.gov.

Features

- ETL C/US Listed for NEMA Type 13 applications - oil / water / coolant spray areas (not submersible) and dusty atmospheres.
- Available with a durable, lightweight, economical, shatter resistant polycarbonate tube housing
- Model 21-TLP-IB-C includes a remote ballast, cordset, and on/off switch
- Stainless steel mounting hardware and fluorescent bulb are included
- 8' long, 18/3 SJTOW cord with NEMA 5-15 plug on models with cords
- EOB units with internal ballast are factory wired for 120V w/ 8' long cordset. Units can be field converted for direct wiring for 90V to 277V. Terminal block provided for easy wire installation.
- Made in U.S.A.

Standard Models

MFG CATALOG NUMBER	MFG MODEL NUMBER	DESCRIPTION	WATTS	VOLTS	LUMENS	OVERALL LENGTH	TUBE MATERIAL	BALLAST INCLUDED	WT. (LBS)	LIST
02823200	21-TLP-IB-C	REMOTE BALLAST WITH CORDSET	36	120V	2900	21"	Polycarbonate	Yes	10	581
04829502	29-TLP-EOB-C	INTERNAL BALLAST WITH CORDSET	36	90 to 277V	2900	29"	Polycarbonate	Yes	7	491
04843402	29-TLP-A	REMOTE BALLAST	50	120V	4300	29"	Polycarbonate	Yes	7	522
04829302	23-TLP-24VDC	INTERNAL BALLAST	18	24VDC *	1250	23"	Polycarbonate	Yes	6	456
04891802	LED MACHINE TOOL LIGHT 21"	LED WITH NO BALLAST	16	120V	1200	21"	Polycarbonate	No	3.44	522
04891902	LED MACHINE TOOL LIGHT 29"	LED WITH NO BALLAST	26	120V	2800	29"	Polycarbonate	No	2.66	581

* Includes 2 ft. lead wires

Notes:

LED lights comply with part 15 of the FCC rule.

LED Machine Tool Light 29" CFL equivalent is 40 watts.

LED Machine Tool Light 21" CFL equivalent is 36 watts.

Accessories - Replacement Lamps

MFG CATALOG NUMBER	MFG MODEL NUMBER	DESCRIPTION	USED WITH	WT. (LBS)	LIST
3103300	TL-RB-18	Fluorescent Replacement Bulb, 18W, PL-L	All 18 Watt Models	1	69
3100800	TL-RB-36	Fluorescent Replacement Bulb, 36W, PL-L	All 36 Watt Models	1	73
3108200	TL-RB-50	Fluorescent Replacement Bulb, 50W, PL-L	All 50 & 100 Watt Models	1	82

Incandescent

Features



WARNING: This product can expose you to chemicals including nickel which is known to the State of California to cause cancer, and chromium, which is known to the State of California to cause birth defects and/or reproductive harm. For more information go to www.P65Warnings.ca.gov.

- Patented disc and collar swivel joints with adjustable bar knobs for securing arms into a variety of positions
- Shades constructed of a 22 Gauge steel and arms made of 3/8" steel tubing, with reach from 29" to 38"
- Charcoal gray powder coated finish
- Horizontal or vertical bolt down mounting bracket
- 10 amp rocker type on-off switch and lamp socket
- Includes an 8' 18/3 SJTO Cordset with NEMA 5-15 molded grounded plug for 120V operation
- LED bulb included
- Made in U.S.A.

Standard Models

MFG CATALOG NUMBER	MFG MODEL NUMBER	BULB TYPE	BULB DESCRIPTION	WATTS	MAX LUMENS	AVE. BULB LIFE (HRS)	OVER-ALL REACH	WT. (LBS)	LIST
03812101	55-VCX-701B	LED	60 Watt Equivalent	11	800	25,000	29"	6	243
03813101	66-VCX-701B						38"		253

Note: 66-VCX-701B is not included in the ETL C/US List

Medium Duty, Flexible Arm, Incandescent, Machine Tool Light

Features



WARNING: This product can expose you to chemicals including nickel which is known to the State of California to cause cancer, and chromium, which is known to the State of California to cause birth defects and/or reproductive harm. For more information go to www.P65Warnings.ca.gov.

- Chrome plated, flexible arm & magnetic base
- 8' 18/3 or 18/2 SPT cordset with molded plug
- Turn knob on-off switch
- Aluminum shade painted white inside
- LED bulb included
- Imported to TPI specifications.

Standard Models

MFG CATALOG NUMBER	MFG MODEL NUMBER	BULB	BASE	MAX LUMENS	OVER-ALL REACH	WT. (LBS)	LIST
04423002	12-R-M-3	8 Watt	Magnetic Base	800	12"	3	172

Illuminated Fluorescent Magnifier

Features



WARNING: This product can expose you to chemicals including nickel which is known to the State of California to cause cancer, and chromium, which is known to the State of California to cause birth defects and/or reproductive harm. For more information go to www.P65Warnings.ca.gov.

- 5", 8-diopter (3X power) magnifying clear lens for 200% magnification of an object with a focal length of 5"
- Suspension spring balanced arm assembly allowing up to 45" reach, with finger tighten control knobs to lock arms and shade into position
- 6' cordset with 2 prong polarized plug
- Housing consists of a sturdy white plastic 8 1/2" shade with an on-off rocker switch and glare protection cover located on the top of the shade
- Includes die-cast clamp-on base to attach to a flat surface up to 2 1/2" thick
- Factory installed 22W, 120V, T-9 deluxe cool white circline fluorescent lamp and protective lens
- Imported to TPI specifications.

Standard Models

MFG CATALOG NUMBER	MFG MODEL NUMBER	MAGNIFICATION POWER	BULB	WATTS	MAX LUMENS	AVE. BULB LIFE (HRS)	OVER-ALL REACH	WT. (LBS)	LIST
04851502	45-MAG-W	3X	22W. Circline	22	1800	16,000	45"	10	262
3120300	MAG-22W	22W., 120V., T-9 deluxe cool white circline replacement lamp						1	35

Product Index Listing

Model	Page	Model	Page	Model	Page	Model	Page
12-R-M-3	49	CACM-P	7	CE 24-D	24	CESM-30	32
1A22-7	41	CACU 20-P	9	CE 24-DS	23	CESM-36	32
2-SW	41	CACU 20-W	9	CE 24-DV	25	CESM-42	32
21-TLP-IB-C	48	CACU 24-P	9	CE 30-D	24	CESM-48	32
23-TLP-24VDC	48	CACU 24-PO	9	CE 30-DS	23	CESM-60	32
24-LDA	47	CACU 24-W	9	CE 30-DV	25	CF-12	18
24-LDF-TE	19	CACU 24-WO	9	CE-24B	26	CF-18	18
29-TLP-A	48	CACU 30-P	9	CE-24B-3	26	CF-20	18
29-TLP-EOB-C	48	CACU 30-P-HD	9	CE-30B	26	CHR-56	22
40-LDA	47	CACU 30-PO	9	CE-30B-3	26	CL-300	44
40-LDF-TE	19	CACU 30-PO-HD	9	CE-36B	26	CLP	43
45-MAG-W	49	CACU 30-W	9	CE-36B-3	26	CPB 30-D	10
55-VCX-701B	49	CACU 30-WO	9	CE-42B	26	CPB 36-B	10
60-LDA	47	CAS - 18	14	CE-42-B-3	26	CPB 36-D	10
60-LDF-TE	19	CAS - 48	14	CE-48B	26	CPB 42-B	10
66-VCX-701B	49	CBT-24B	31	CE-48-B-3	26	CPB 48-B	10
ACH 20	7	CBT-24B-3	31	CEFP-12	34	CPBS 24-DHV	10
ACH 20-O	5	CBT-30B	31	CEFP-16	34	CPBS 30-D	10
ACH 24	5	CBT-30B-3	31	CEFP-18	34	CRT	43
ACH 24-EX1	8	CBT-36B	31	CEFP-20	34	CS-10-W	41
ACH 24-EX3	8	CBT-36B-3	31	CEFP-24	34	CS-13-W	41
ACH 24-O	5	CBT-42B	31	CEFP-30	34	CS-14-W	41
ACH 24-TE3	8	CBT-42B-3	31	CEFP-36	34	CS-18-W	41
ACH 30-TE3	8	CBT-48B	31	CEFP-42	34	CS-19-W	41
ACH 30	5	CBT-48B-3	31	CEFP-48	34	DKL-25-FLX	46
ACH 30-EX1	8	CD-18	35	CEFP-60	34	DKL-40VA-A	46
ACH 30-EX3	8	CD-24	35	CES 12-HD	32	DKL-40VA-ARM	47
ACH 30-O	5	CD-30	35	CES 16-HD	32	DKL-40VA-FL-A	46
ACM-C	2, 5, 7, 8	CD-36	35	CES 18-HD	32	DKL-40VA-LED	46
ACM-I	2, 5, 7, 8	CD-42	35	CES 20-HD	32	DKL-40VA-QH-A	46
ACM-P	2, 5, 7, 8	CD-48	35	CES 24-HD	26, 32	DKL-60VA-A	46
ACM-PM	2, 5, 7, 8	CD-54	35	CES 30-HD	26, 32	DKL-60VA-ARM	47
ACM-S	2, 5, 7, 8	CD-60	35	CES 36-HD	26, 32	DKL-60VA-FL-A	46
ACM-W	2, 5, 7, 8	CE 10-D	24	CES 42-HD	26, 32	DKL-60VA-LED	46
ACM-WK	2, 4, 5, 7, 8	CE 10-DS	23	CES 48-HD	26, 32	DKL-60VA-QH-A	46
ACU 20-P	7	CE 10-DV	25	CES 54-HD	32	DKL-FL	19, 47
ACU 20-PO	7	CE 12-D	24	CES 60-HD	32	DKL-INC	19, 47
ACU 20-W	7	CE 12-DS	23	CES-10G	24, 25	DKL-LED	19, 47
ACU 20-WO	7	CE 12-DV	25	CES-12G	24, 25	DKL-LED-37	47
ACU 24-P	6	CE 14-D	24	CES-14G	24, 25	DKL-QH	19, 47
ACU 24-PO	6	CE 14-DS	23	CES-16G	24, 25	DLGL	46
ACU 24-W	6	CE 14-DV	25	CES-18G	24, 25	DLGS	46
ACU 24-WO	6	CE 16-D	24	CES-20G	24, 25	DMKP1	35
ACU 30-P	6	CE 16-DS	23	CES-24	26	DMKP2	35
ACU 30-PO	6	CE 16-DV	25	CES-24G	24, 25	EHB24-1	30
ACU 30-W	6	CE 18-D	24	CES-30	26	EHB24-1-3	30
ACU 30-WO	6	CE 18-DS	23	CES-30G	24, 25	EHB24-1/2	30
AGD-1616B-G	41	CE 18-DV	25	CES-36	26	EHB24-1/2-3	30
BD24-2-WHS	41	CE 20-D	24	CES-42	26	EHB24-1/4	30
BD30-2-WHS	41	CE 20-DS	23	CES-48	26	EHB24-1/4-3	30
BD36-2-WHS	41	CE 20-DV	25	CESM-24	32	EHB24-3/4	30

<i>Model</i>	<i>Page</i>	<i>Model</i>	<i>Page</i>	<i>Model</i>	<i>Page</i>	<i>Model</i>	<i>Page</i>
EHB24-3/4-3	30	EHB60-1 1/2	30	EHD36-5-3	29	HDH 24-G	5
EHB30-1	30	EHB60-1 1/2-3	30	EHD42-1-3	29	HDH 24-GJR	2
EHB30-1 1/2	30	EHB60-1-3	30	EHD42-2	29	HDH 24-JR	2
EHB30-1 1/2-3	30	EHB60-2	30	EHD42-2-3	29	HDH 30	4
EHB30-1-3	30	EHB60-2-3	30	EHD42-3-3	29	HDH 30-G	5
EHB30-1/2	30	EHB60-3-3	30	EHD42-5-3	29	HDH 30-GJR	2
EHB30-1/2-3	30	EHB60-5-3	30	EHD48-3-3	29	HDH 30-JR	2
EHB30-1/3	30	EHD12-1/4	29	EHD48-5-3	29	HDHR-56	22
EHB30-1/3-3	30	EHD12-1/4-3	29	EHD60-10-3	29	HDHR-56WR	22
EHB30-1/4	30	EHD16-1/4	29	EHD60-3-3	29	HDHR-60	22
EHB30-1/4-3	30	EHD16-1/4-3	29	EHD60-5-5	29	HDHR-60WR	22
EHB30-3/4	30	EHD18-1/2	29	EHD60-7 1/2-3	29	HDM-C	2, 4, 7
EHB30-3/4-3	30	EHD18-1/2-3	29	EMF-12	33	HDM-I	2, 4, 7
EHB36-1	30	EHD18-1/3	29	EMF-16	33	HDM-P	2, 4, 7
EHB36-1 1/2	30	EHD18-1/3-3	29	EMF-20	33	HDM-W	2, 4, 7
EHB36-1 1/2-3	30	EHD20-1	29	EMF-24	33	HR-GUARD	22
EHB36-1-3	30	EHD20-1-3	29	EMF-30	33	IBG-12	33
EHB36-1/2	30	EHD20-1/2	29	EMF-36	33	IBG-16	33
EHB36-1/2-3	30	EHD20-1/2-3	29	EMF-42	33	IBG-18	33
EHB36-1/3	30	EHD20-1/4	29	EMF-48	33	IBG-20	33
EHB36-1/3-3	30	EHD20-1/4-3	29	EMF-60	33	IBG-24	33
EHB36-2	30	EHD24-1	29	EVAP16HD	21	IBG-30	33
EHB36-2-3	30	EHD24-1-3	29	EVAP24HD	21	IBG-36	33
EHB36-3/4	30	EHD24-1/2	29	EVAP36HD	21	IBG-42	33
EHB36-3/4-3	30	EHD24-1/2-3	29	EVAP36-HAZ	20	IBG-48	33
EHB42-1	30	EHD24-1/3	29	EVAP48HD	21	IBG-60	33
EHB42-1 1/2	30	EHD24-1/3-3	29	EVAP48-HAZ	20	IE24-1	28
EHB42-1 1/2-3	30	EHD24-1/4	29	F-12-TE	17	IE24-1-3	28
EHB42-1-3	30	EHD24-1/4-3	29	F-18-CR	17	IE24-1/2	28
EHB42-1/2	30	EHD24-2	29	F-18-TE	17	IE24-1/2-3	28
EHB42-1/2-3	30	EHD24-2-3	29	F-18H-CR	17	IE24-1/3	28
EHB42-1/3	30	EHD24-3-3	29	F-18H-TE	17	IE24-1/3-3	28
EHB42-1/3-3	30	EHD24-3/4	29	F-24-CR	17	IE24-3/4	28
EHB42-2	30	EHD24-3/4-3	29	F-24-TE	17	IE24-3/4-3	28
EHB42-2-3	30	EHD30-1 1/2	29	F-24-TE-HV	17	IE30-1	28
EHB42-3-3	30	EHD30-1 1/2-3	29	F-24H-CR	17	IE30-1-3	28
EHB42-3/4	30	EHD30-1-3	29	F-24H-TE	17	IE30-1/2	28
EHB42-3/4-3	30	EHD30-1/2	29	F-LED-31-1	43	IE30-1/2-3	28
EHB48-1	30	EHD30-1/2-3	29	FL-1	43	IE30-1/3	28
EHB48-1 1/2	30	EHD30-1/3	29	FL-2	43	IE30-1/3-3	28
EHB48-1 1/2-3	30	EHD30-1/3-3	29	FLR	43	IE30-3/4	28
EHB48-1-3	30	EHD30-2	29	FLS-18	35	IE30-3/4-3	28
EHB48-1/2	30	EHD30-2-3	29	FLS-24	35	IE36-1	28
EHB48-1/2-3	30	EHD30-3-3	29	FLS-30	35	IE36-1 1/2	28
EHB48-2	30	EHD30-3/4	29	FLS-36	35	IE36-1 1/2-3	28
EHB48-2-3	30	EHD30-3/4-3	29	FLS-42	35	IE36-1-3	28
EHB48-3-3	30	EHD36-1	29	FLS-48	35	IE36-1/2	28
EHB48-3/4	30	EHD36-1-3	29	FLS-54	35	IE36-1/2-3	28
EHB48-3/4-3	30	EHD36-2	29	FLS-60	35	IE36-1/3	28
EHB48-5-3	30	EHD36-2-3	29	GV-405-2B-G	41	IE36-1/3-3	28
EHB60-1	30	EHD36-3-3	29	HDH 24	4	IE36-2	28

Product Index Listing

Model	Page	Model	Page	Model	Page	Model	Page
IE36-2-3	28	IHR-56-277V	22	MCD60-3	14	PM-18C	22
IE36-3/4	28	IHR-56R	22	MCD60-5	14	PM-18FO	22
IE36-3/4-3	28	KBWC-110K	22	MCD60-7 1/2	14	PM-18S	22
IE42-1	28	KBWC-13K	22	MK-1	32	PM-2	18
IE42-1 1/2	28	KBWC-15K	22	MK-2	32	PM-2.5	18
IE42-1 1/2-3	28	KBWC-15SK	22	MK-3	32	PM-3	18
IE42-1-3	28	KBWC-310K	22	N-12	19	PUL-1000Q-CD	44
IE42-2	28	LDF-18-TE	47	NK-PM18	22	PUL-1000Q-TC	44
IE42-2-3	28	LED-1	43	ODF-12	18	QH-1	43
IE42-3-3	28	LED-12	43, 46	ODF-16	18	QH-2	43
IE42-3/4	28	LED-2	43	OSF-16	18	R1-MOT	2
IE42-3/4-3	28	LED-37-1	43	PADEVAP16HD	21	R2-MOT	3
IE48-1	28	LED-37-2	43	PADEVAP24HD	21	RDS-18	35
IE48-1 1/2	28	LG-1	46	PADEVAP36HD	21	RDS-24	35
IE48-1 1/2-3	28	M-LED-37-1	43	PADEVAP48HD	21	RDS-30	35
IE48-1-3	28	MAG	43	PADEVAP-Mini700	21	RDS-36	35
IE48-2	28	MAG-22W	49	PB 30-D	11	RDS-42	35
IE48-2-3	28	MB 24-DF	16	PB 36-B	12	RDS-48	35
IE48-3-3	28	MB 24-DY	16	PB 36-B-3	12	RDS-54	35
IE48-3/4	28	MB 30-DF	16	PB 36-B-HL	12	RDS-60	35
IE48-3/4-3	28	MB 30-DY	16	PB 36-D	11	RE24-1	36
IE48-5-3	28	MBM-W	16	PB 42-B	12	RE24-1-3	36
IE60-2	28	MCD18-1	14, 15	PB 42-B-3	12	RE24-1/2	36
IE60-2-3	28	MCD18-1/3	14, 15	PB 42-B-HL	12	RE24-1/2-3	36
IE60-3-3	28	MCD18-1/4	14, 15	PB 42-D	11	RE24-1/4	36
IE60-5-3	28	MCD24-1	14, 15	PB 48-B	12	RE24-1/4-3	36
IED12-1/4	27	MCD24-1 1/2	14, 15	PB 48-B-3	12	RE24-3/4	36
IED12-1/4-3	27	MCD24-1/2	14, 15	PB 48-B-HL	12	RE24-3/4-3	36
IED16-1/3	27	MCD24-1/3	14, 15	PB 48-D-OP	11	RE30-1	36
IED16-1/3-3	27	MCD24-1/4	14, 15	PBS 30-D	11	RE30-1 1/2	36
IED18-1/2	27	MCD24-3	14, 15	PBS 36-B	12	RE30-1 1/2-3	36
IED18-1/2-3	27	MCD24-3/4	14, 15	PBS 36-B-3	12	RE30-1-3	36
IED20-3/4	27	MCD30-1	14, 15	PBS 36-B-HL	12	RE30-1/2	36
IED20-3/4-3	27	MCD30-1 1/2	14, 15	PBS 36-D	11	RE30-1/2-3	36
IED24-1	27	MCD30-1/2	14, 15	PBS 42-B	12	RE30-1/3	36
IED24-1-3	27	MCD30-1/3	14, 15	PBS 42-B-3	12	RE30-1/3-3	36
IED30-1	27	MCD30-2	14, 15	PBS 42-B-HL	12	RE30-3/4	36
IED30-1-3	27	MCD30-3	14, 15	PBS 42-D	11	RE30-3/4-3	36
IED36-1 1/2	27	MCD30-3/4	14, 15	PBS 48-B	12	RE36-1	36
IED36-1 1/2-3	27	MCD36-1	14, 15	PBS 48-B-3	12	RE36-1 1/2	36
IED42-2-3	27	MCD36-1 1/2	14, 15	PBS 48-B-HL	12	RE36-1 1/2-3	36
IED48-3-3	27	MCD36-2	14, 15	PBS 48-D-OP	11	RE36-1-3	36
IHP 20-H-WD	8	MCD36-3	14, 15	PCBT 36-B	16	RE36-1/2	36
IHP 24-H	5	MCD36-5	14, 15	PCBT 42-B	16	RE36-1/2-3	36
IHP 24-H-277	8	MCD42-2	14	PCBT 48-B	16	RE36-1/3	36
IHP 24-H-WD	8	MCD42-5	14	PDV-305-1MB-BLK-G	41	RE36-1/3-3	36
IHP 30-H	5	MCD48-10	14	PDV-305-1MB-BR-G	41	RE36-2	36
IHP 30-H-277	8	MCD48-5	14	PDV-305-1MB-GY-G	41	RE36-2-3	36
IHP 30-H-WD	8	MCD48-7 1/2	14	PED	43	RE36-3/4	36
IHR-48	22	MCD60-10	14	PM-1	18	RE36-3/4-3	36
IHR-56	22	MCD60-15	14	PM-1.5	18	RE42-1	36

<i>Model</i>	<i>Page</i>	<i>Model</i>	<i>Page</i>	<i>Model</i>	<i>Page</i>	<i>Model</i>	<i>Page</i>
RE42-1 1/2	36	SB 48-B-3	13	TXB15-1/4	40	TXB42-2	40
RE42-1 1/2-3	36	SB 48-B-HL	13	TXB15-1/4-3	40	TXB42-2-3	40
RE42-1-3	36	SCK-12	2, 3	TXB15-3/4	40	TXB42-3-3	40
RE42-1/2	36	SF-12	33	TXB15-3/4-3	40	TXB42-5-3	40
RE42-1/2-3	36	SF-16	33	TXB18-1	40	TXB48-5-3	40
RE42-2	36	SF-18	33	TXB18-1 1/2	40	TXB48-7 1/2-3	40
RE42-2-3	36	SF-20	33	TXB18-1 1/2-3	40	TXD12-1/2	39
RE42-3-3	36	SF-24	33	TXB18-1-3	40	TXD12-1/2-3	39
RE42-3/4	36	SLS-18	35	TXB18-1/2	40	TXD12-1/4	39
RE42-3/4-3	36	SLS-24	35	TXB18-1/2-3	40	TXD12-1/4-3	39
RE48-1	36	SLS-30	35	TXB18-1/3	40	TXD12-3/4	39
RE48-1 1/2	36	SLS-36	35	TXB18-1/3-3	40	TXD12-3/4-3	39
RE48-1 1/2-3	36	SLS-42	35	TXB18-1/4	40	TXD18-1	39
RE48-1-3	36	SLS-48	35	TXB18-1/4-3	40	TXD18-1-3	39
RE48-2	36	SLS-54	35	TXB24-1	40	TXD18-1/2	39
RE48-2-3	36	SLS-60	35	TXB24-1 1/2	40	TXD18-1/2-3	39
RE48-3-3	36	SR-12	33	TXB24-1 1/2-3	40	TXD18-1/3	39
RE48-3/4	36	SR-16	33	TXB24-1-3	40	TXD18-1/3-3	39
RE48-3/4-3	36	SR-18	33	TXB24-1/2	40	TXD18-1/4	39
RE48-5-3	36	SR-20	33	TXB24-1/2-3	40	TXD18-1/4-3	39
RE54-1	36	SR-24	33	TXB24-2	40	TXD24-1	39
RE54-1 1/2	36	SSE-55	43, 46	TXB24-2-3	40	TXD24-1-3	39
RE54-1 1/2-3	36	SW-1	14	TXB24-3-3	40	TXD24-1/2	39
RE54-1-3	36	SW-1 1/2	14	TXB24-3/4	40	TXD24-1/2-3	39
RE54-2	36	SW-1 1/2-3	14	TXB24-3/4-3	40	TXD24-1/3	39
RE54-2-3	36	SW-1-3	14	TXB27-1	40	TXD24-1/3-3	39
RE54-3-3	36	SW-1/2	14	TXB27-1 1/2	40	TXD24-1/4	39
RE54-5-3	36	SW-1/2-3	14	TXB27-1 1/2-3	40	TXD24-1/4-3	39
RE60-1	36	SW-1/4	14	TXB27-1-3	40	TXD24-2	39
RE60-1 1/2	36	SW-1/4-3	14	TXB27-2	40	TXD24-2-3	39
RE60-1 1/2-3	36	SW-2-3	14	TXB27-2-3	40	TXD24-3-3	39
RE60-1-3	36	SW-3-3	14	TXB27-3/4	40	TXD24-3/4	39
RE60-2	36	SW-5-3	14	TXB27-3/4-3	40	TXD24-3/4-3	39
RE60-2-3	36	SW-7 1/2-3	14	TXB30-1	40	TXD27-1	39
RE60-3-3	36	TL-RB-18	48	TXB30-1 1/2	40	TXD27-1-3	39
RE60-5-3	36	TL-RB-36	48	TXB30-1 1/2-3	40	TXD27-1/2	39
RE60-7 1/2-3	36	TL-RB-50	48	TXB30-1-3	40	TXD27-1/2-3	39
RS 06-EC	2, 3	TRI	43	TXB30-1/2	40	TXD27-2	39
RS 09-EC	2, 3	TRI-HD	44	TXB30-1/2-3	40	TXD27-2-3	39
RS 12-EC	2, 3	TXB12-1/2	40	TXB30-2	40	TXD30-1/2	39
RS 15-EC	2, 3	TXB12-1/2-3	40	TXB30-2-3	40	TXD30-1/2-3	39
SB 30-D	13	TXB12-1/3	40	TXB30-3-3	40	TXD30-2	39
SB 36-B	13	TXB12-1/3-3	40	TXB30-5-3	40	TXD30-2-3	39
SB 36-B-3	13	TXB12-1/4	40	TXB34-1 1/2	40	TXD30-3-3	39
SB 36-B-HL	13	TXB12-1/4-3	40	TXB34-1 1/2-3	40	TXD30-3/4	39
SB 36-D	13	TXB12-3/4	40	TXB34-2	40	TXD30-3/4-3	39
SB 42-B	13	TXB12-3/4-3	40	TXB34-2-3	40	TXD34-1 1/2	39
SB 42-B-3	13	TXB15-1/2	40	TXB34-3-3	40	TXD34-1 1/2-3	39
SB 42-B-HL	13	TXB15-1/2-3	40	TXB34-5-3	40	TXD34-2	39
SB 42-D	13	TXB15-1/3	40	TXB42-1 1/2	40	TXD34-2-3	39
SB 48-B	13	TXB15-1/3-3	40	TXB42-1 1/2-3	40	TXD34-3-3	39

Product Index Listing

Model	Page	Model	Page	Model	Page
TXD34-5-3	39	UEB42-2	38	UED36-2	37
TXD36-2	39	UEB42-2-3	38	UED36-2-3	37
TXD36-2-3	39	UEB42-3-3	38	UED36-3-3	37
TXD36-3-3	39	UEB42-3/4	38	UED36-5-3	37
TXD42-1-3	39	UEB42-3/4-3	38	UED42-2	37
TXD42-2	39	UEB48-1	38	UED42-2-3	37
TXD42-2-3	39	UEB48-1 1/2	38	UED42-5-3	37
TXD42-3-3	39	UEB48-1 1/2-3	38	UED48-10-3	37
TXD42-5-3	39	UEB48-1-3	38	UED48-3-3	37
TXD48-3-3	39	UEB48-2	38	UED48-5-3	37
TXD48-5-3	39	UEB48-2-3	38	UED48-7 1/2-3	37
TXG-12	39	UEB48-3-3	38	UED60-5-3	37
TXG-15	39	UEB48-3/4	38	UED60-7 1/2-3	37
TXG-18	39	UEB48-3/4-3	38	UHP 24-CJR	3
TXG-24	39	UEB54-1	38	UHP 24-IJR	3
TXG-27	39	UEB54-1 1/2	38	UHP 24-P	6
TXG-30	39	UEB54-1 1/2-3	38	UHP 24-PJR	3
TXG-34	39	UEB54-1-3	38	UHP 24-SJR	3
TXG-36	39	UEB54-2	38	UHP 24-W	6
TXG-42	39	UEB54-2-3	38	UHP 24-WJR	3
TXG-48	39	UEB54-3-3	38	UHP 30-CJR	3
U-12-TE	18	UEB54-5-3	38	UHP 30-IJR	3
U-18-CR	17	UEB60-1 1/2	38	UHP 30-P	6
U-18-TE	18	UEB60-1 1/2-3	38	UHP 30-PJR	3
U-24-CR	17	UEB60-2	38	UHP 30-SJR	3
U-24-TE	18	UEB60-2-3	38	UHP 30-W	6
U-24-TE-HV	18	UEB60-3-3	38	UHP 30-WJR	3
UEB24-1/2	38	UEB60-5-3	38	WACM-P	7
UEB24-1/2-3	38	UED18-1	37	WACM-W	7
UEB24-1/3	38	UED18-1-3	37	WH-12	34
UEB24-1/3-3	38	UED18-1/2	37	WH-16	34
UEB24-3/4	38	UED18-1/2-3	37	WH-18	34
UEB24-3/4-3	38	UED18-1/3	37	WH-20	34
UEB30-1	38	UED18-1/3-3	37	WH-24	34
UEB30-1-3	38	UED18-1/4	37	WH-30	34
UEB30-1/2	38	UED18-1/4-3	37	WH-36	34
UEB30-1/2-3	38	UED24-1	37	WH-42	34
UEB30-3/4	38	UED24-1-3	37	WH-48	34
UEB30-3/4-3	38	UED24-1/4	37	WH-60	34
UEB36-1	38	UED24-1/4-3	37	X3	22
UEB36-1 1/2	38	UED24-3-3	37		
UEB36-1 1/2-3	38	UED24-3/4	37		
UEB36-1-3	38	UED24-3/4-3	37		
UEB36-1/2	38	UED30-1 1/2	37		
UEB36-1/2-3	38	UED30-1 1/2-3	37		
UEB36-3/4	38	UED30-1-3	37		
UEB36-3/4-3	38	UED30-2	37		
UEB42-1	38	UED30-2-3	37		
UEB42-1 1/2	38	UED30-3-3	37		
UEB42-1 1/2-3	38	UED30-3/4	37		
UEB42-1-3	38	UED30-3/4-3	37		

